



Il Modello Standard

... da un punto di vista sperimentale

Luca Lista

INFN



Cos'è il Modello Standard?



- È un **modello matematico** che descrive:
 - Le particelle che costituiscono tutta la materia che conosciamo
 - Le loro interazioni (= forze) fondamentali
- È un esempio di **unificazione** delle interazioni fondamentali
- **Non descrive tutti i fenomeni noti**
 - Es.: **gravità, materia oscura**
- **Non tutte le sue previsioni sono state confermate**
 - Il **bosone di Higgs** non è ancora stato scoperto



La materia è fatta da atomi

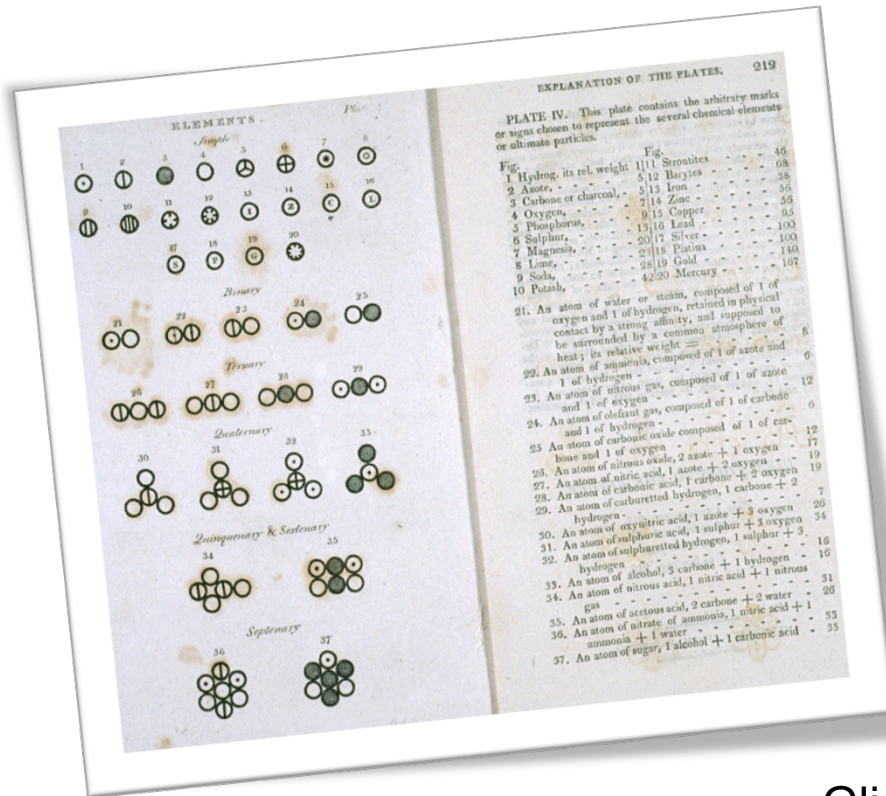

John Dalton,
A New System of Chemical Philosophy (1808),

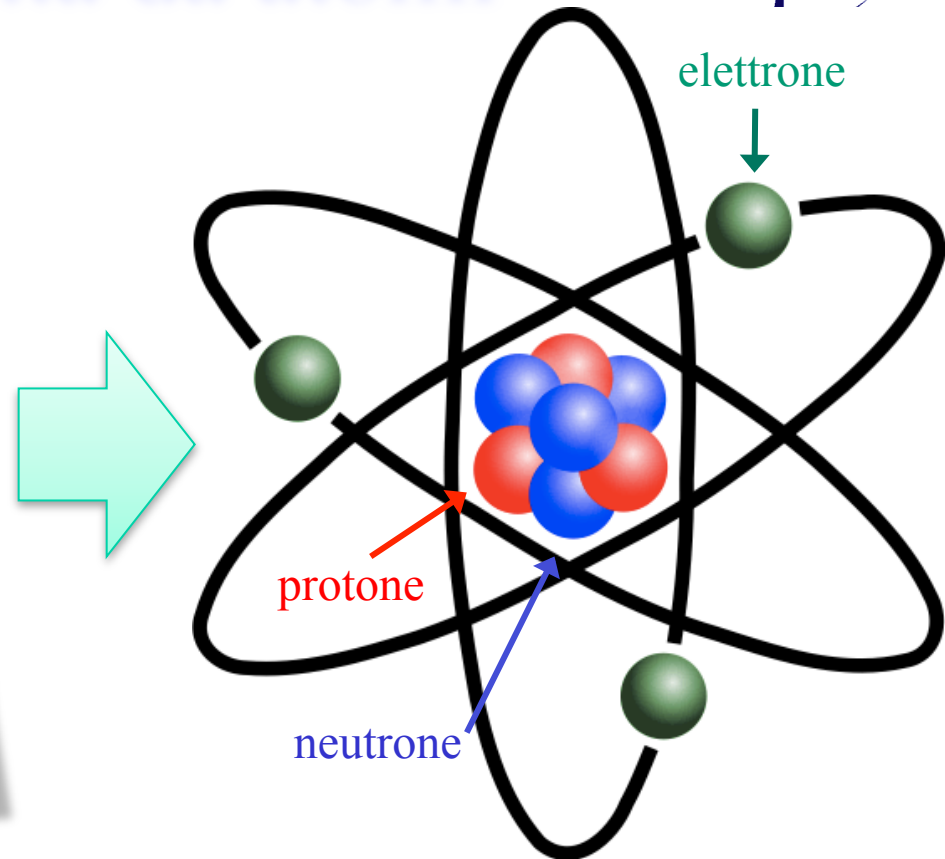

Gli elettroni (-) e il nucleo (+) sono tenuti insieme dalla **forza elettrica**
Una **forza (forte)** deve tenere insieme protoni e neutroni dentro il nucleo, che altrimenti si respingerebbero per la forza coulombiana

- Alcuni nuclei atomici decadono emettendo **elettroni** (radiazione β). Nel decadimento un **neutrone** si trasforma in un **protone**
- Deve essere emessa una particella invisibile (**neutrino**) che garantisce la conservazione di energia e momento

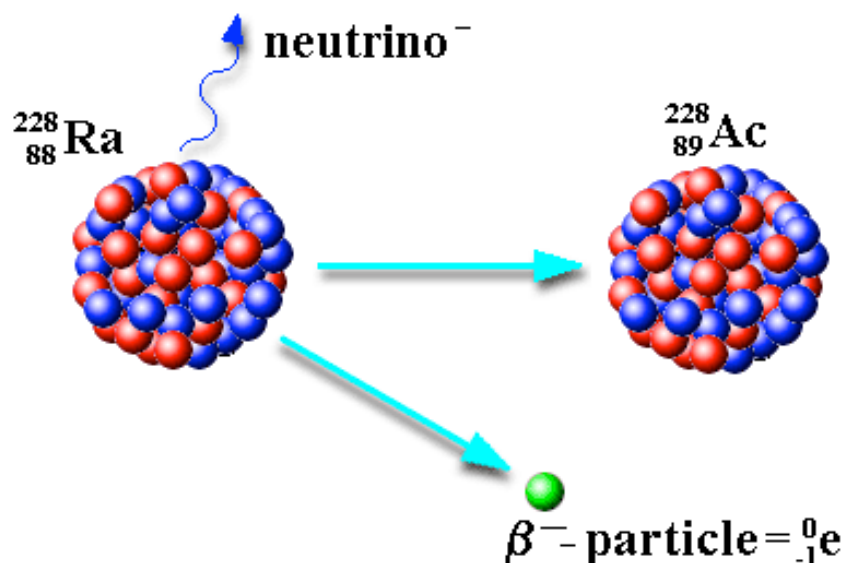

I decadimenti β avvengono con la reazione:



La rarità dei decadimenti β indica che sono dovuti ad un'interazione $\sim 10^{11}$ volte più **debole** della forza elettromagnetica



Nuove particelle



- Le prime sorgenti di particelle di alta energia sono stati i **raggi cosmici**
- L'introduzione di **nuove tecniche di rivelazione** ha portato alla scoperta di **nuovi tipi di particelle** e delle loro possibili interazioni con **protoni**, **neutroni** e **elettroni** della materia che conosciamo

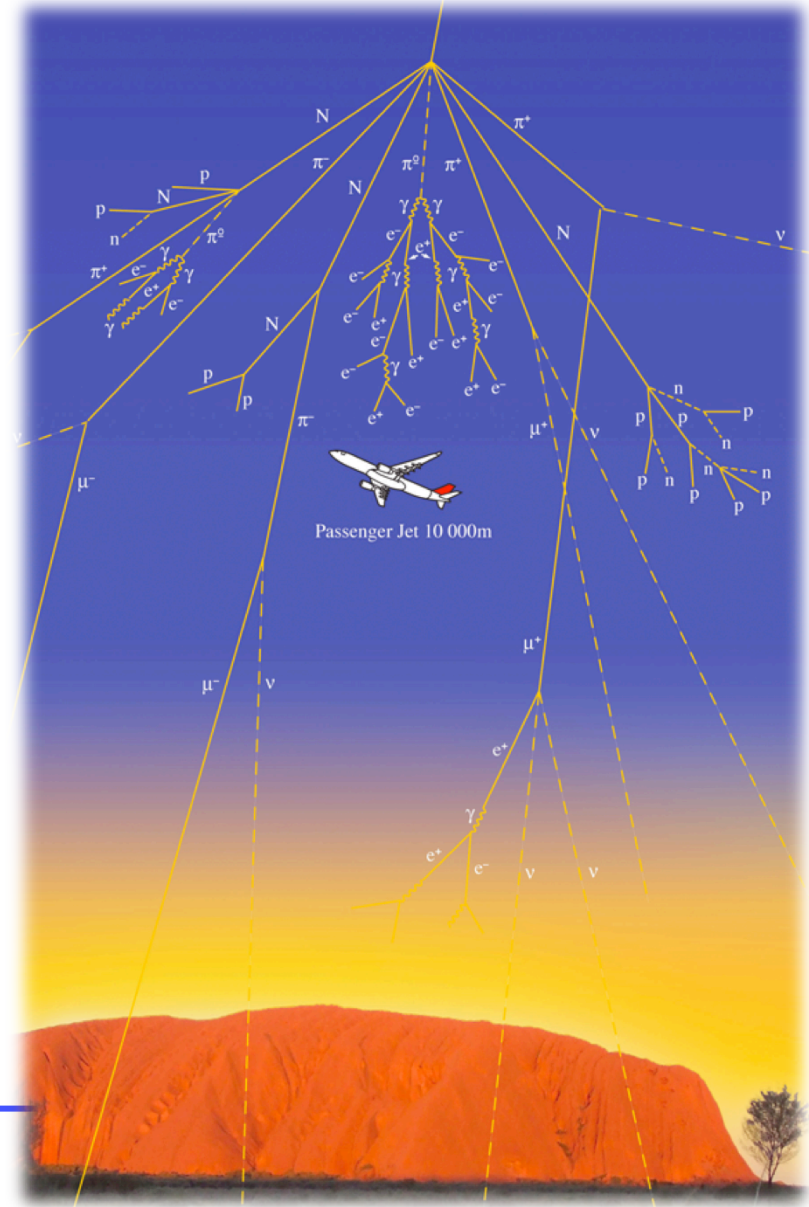
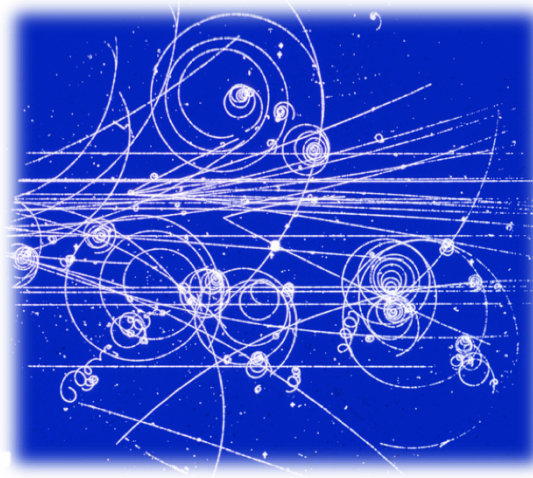



L'antimateria



- Paul Dirac estese l'equazione di Schrödinger alla relatività di Einstein ed ha previsto particelle con **energia negativa**, equivalenti a stati con carica elettrica opposta a quella delle particelle ordinarie

$$(-i\gamma^\mu \partial_\mu + m)\psi = 0$$

- Il **positrone** (e^+) è stato scoperto da **Carl Anderson** osservando i raggi cosmici nel 1932, pochi anni dopo la previsione di Dirac

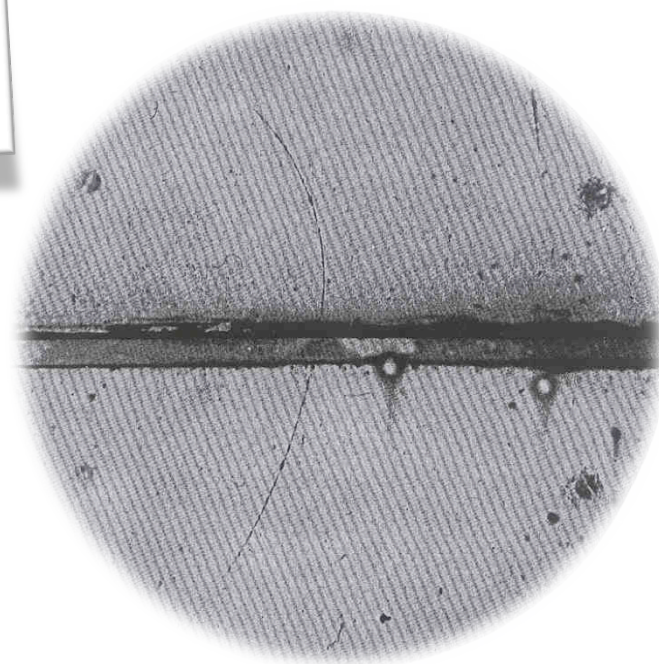



Il muone



- La particella più abbondante che è presente nei raggi cosmici è il **muone**, scoperto da Anderson nel 1936
- Il μ è del tutto simile all'elettrone ma circa 200 volte più pesante
- Il muone è **instabile**, e decade ad un certo punto del suo percorso in **elettrone** e **neutrini**
- I muoni sono le particelle cariche più **penetranti**, possono attraversare spessi strati di materia
- Circa **~ 100 muoni al secondo** raggiungono **ogni metro quadrato** del suolo terrestre

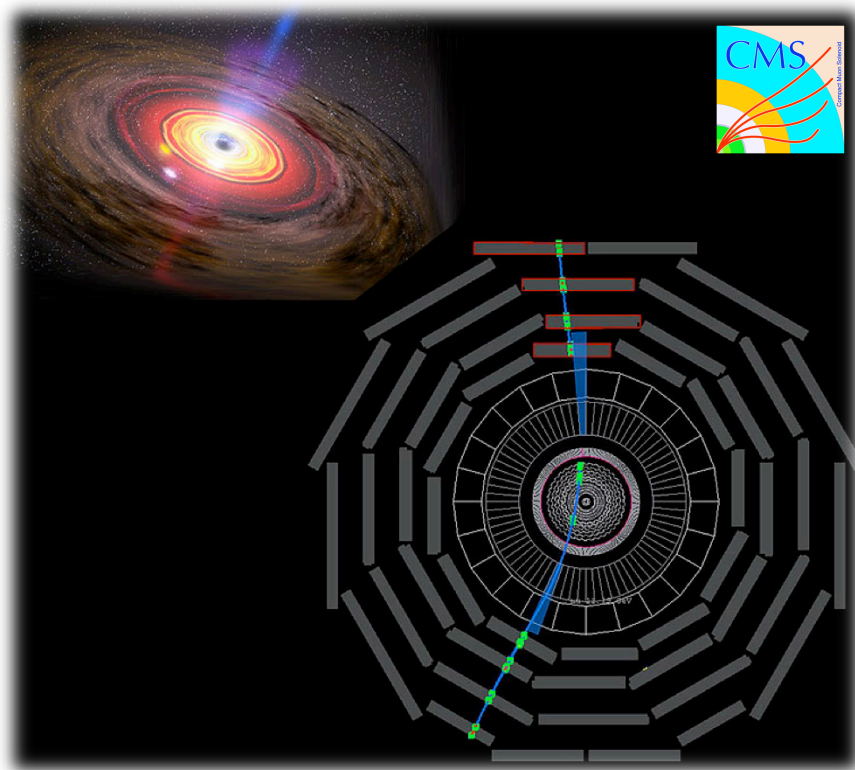



I quark



- Il **pione** fu scoperto nei raggi cosmici nel 1947, al quale seguì la scoperta di nuovi tipi di particelle instabili che decadevano ciascuna in altre particelle
- La presenza dei diversi tipi di particelle può essere spiegata in termini di costituenti elementari: i **quark**, con carica elettrica multipla di $1/3$
- Protone e neutrone sono costituiti da tre quark, Il pione è composto da un quark ed un anti-quark

Up: $+ 2/3$

Down: $-1/3$

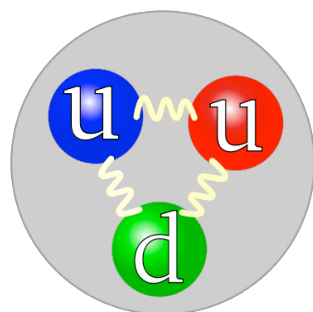

Protone: +1

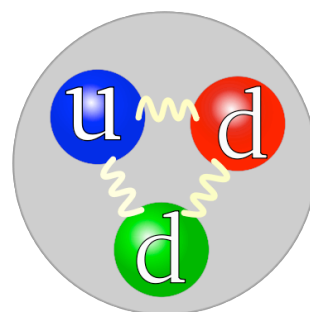

Neutrone: 0

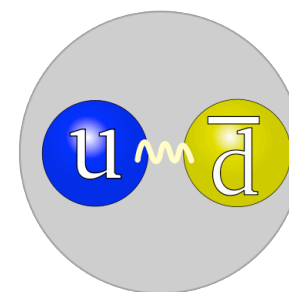

Pione $-\pi^+$



Il quark “strano”



- Nel 1947 fu scoperta in interazioni con i raggi cosmici una particella che decadeva in due pioni: $K \rightarrow \pi^+ \pi^-$, ma di massa molto maggiore del pione
- Seguirono, soprattutto grazie all'uso degli **acceleratori**, scoperte di **numerose particelle** instabili che potevano **decadere** le une nelle altre, con precise regole di selezione
- Le diverse particelle si spiegavano con l'introduzione del terzo **quark strano**

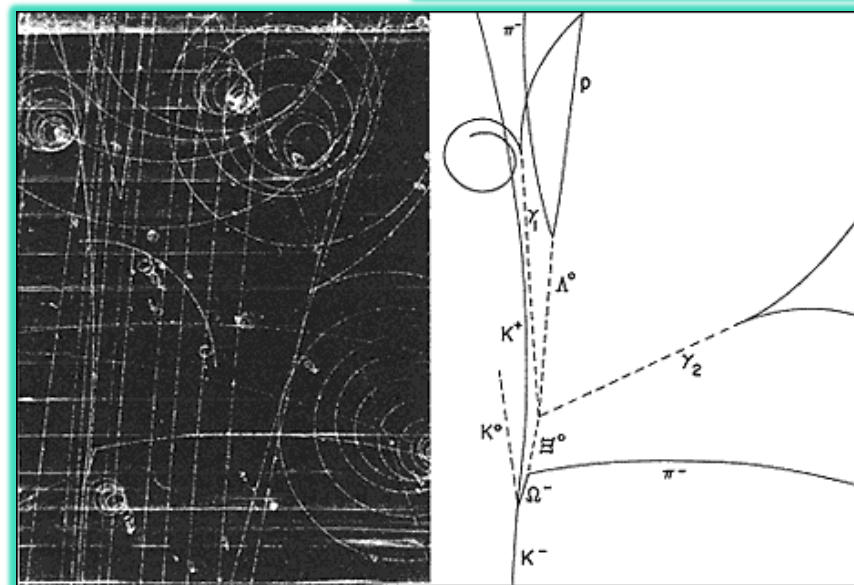
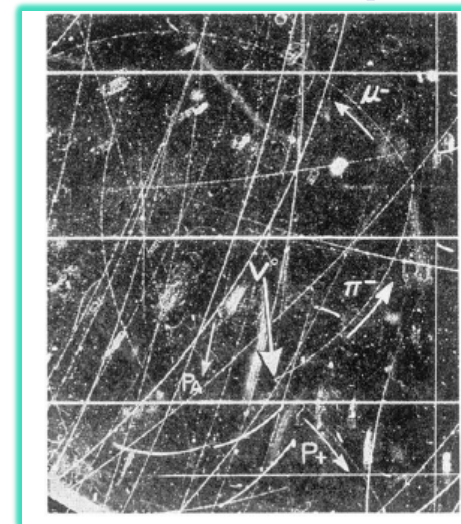



Quark e anti-quark



- Il modello a quark è come la **tavola periodica degli elementi** delle particelle
- Coppie quark + anti-quark formano i **mesoni**, tra i quali il **pione** e i **kaoni**

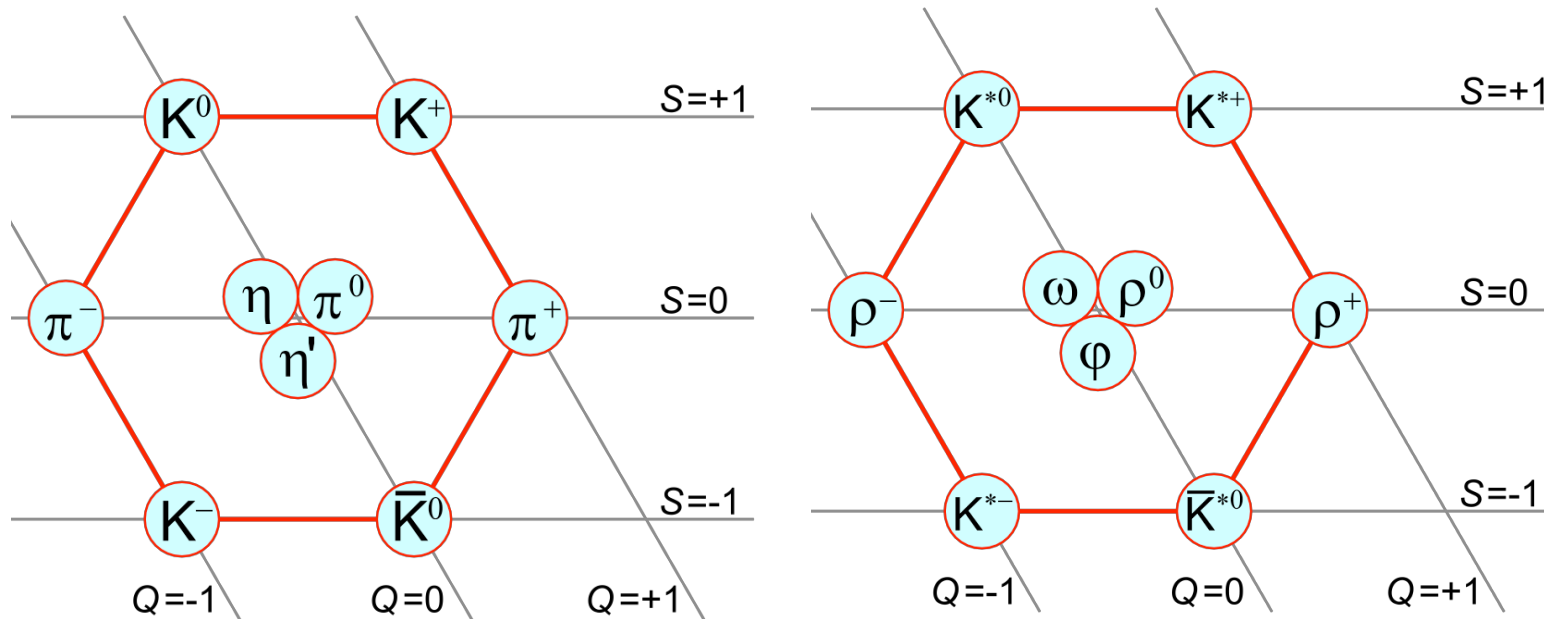



Mesoni e barioni



- Terne di quark formano i **barioni**, tra i quali il **protone** e il **neutrone**

materia ordinaria

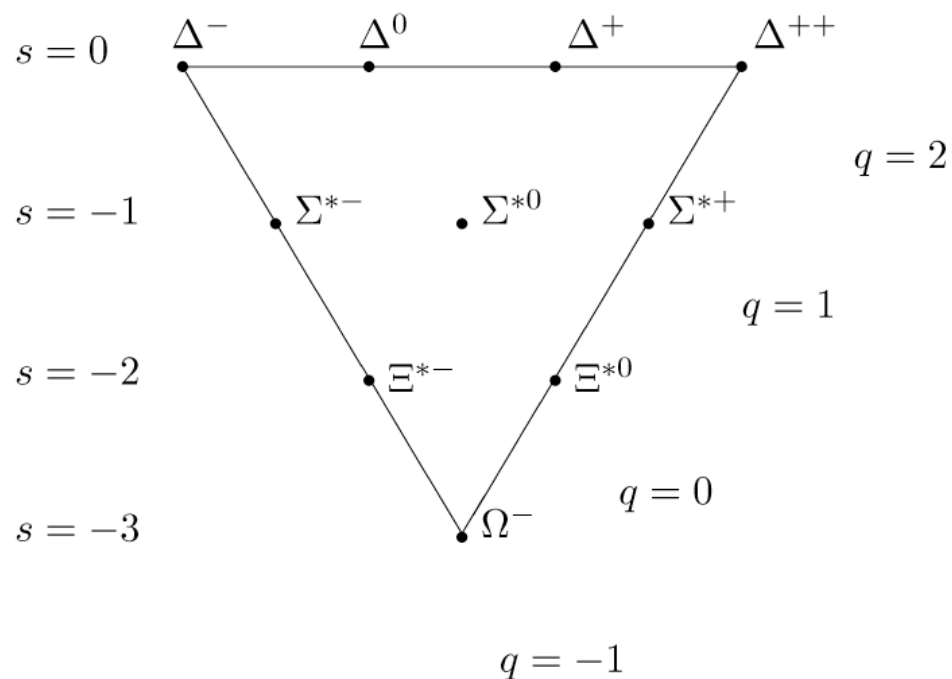
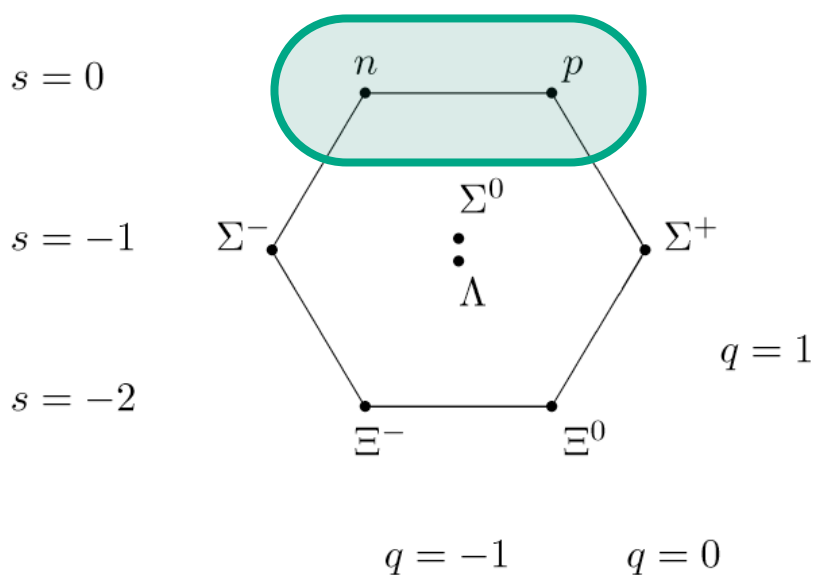



Interazioni e simmetrie



- La presenza di **particelle che mediano le interazioni fondamentali** si può collegare con **principi di simmetria** dei campi quantistici di materia
- Questo viene formulato matematicamente nelle **teorie di gauge**
- L'interazione elettromagnetica si può introdurre con l'**invarianza di gauge U(1)** della funzione d'onda degli elettroni, dando luogo all'**elettrodinamica quantistica (QED)**
 - La particella che media l'interazione e.m. è il **fotone**, che è elettricamente **neutro**
- Allo stesso modo, anche l'interazione forte può essere descritta dalla **cromodinamica quantistica (QCD)**, ma con una simmetria **SU(3)**
 - La particella che media l'interazione forte è il **gluone**
 - La presenza di tre tipi di carica forte nei quark ("colore": **rosso**, **verde**, **blu**), e che i gluoni sono tutti "carichi" di carica forte spiega il confinamento dei quark all'interno di mesoni e barioni
- Anche le interazioni deboli discendono da un principio di simmetria, ma con qualche complicazione

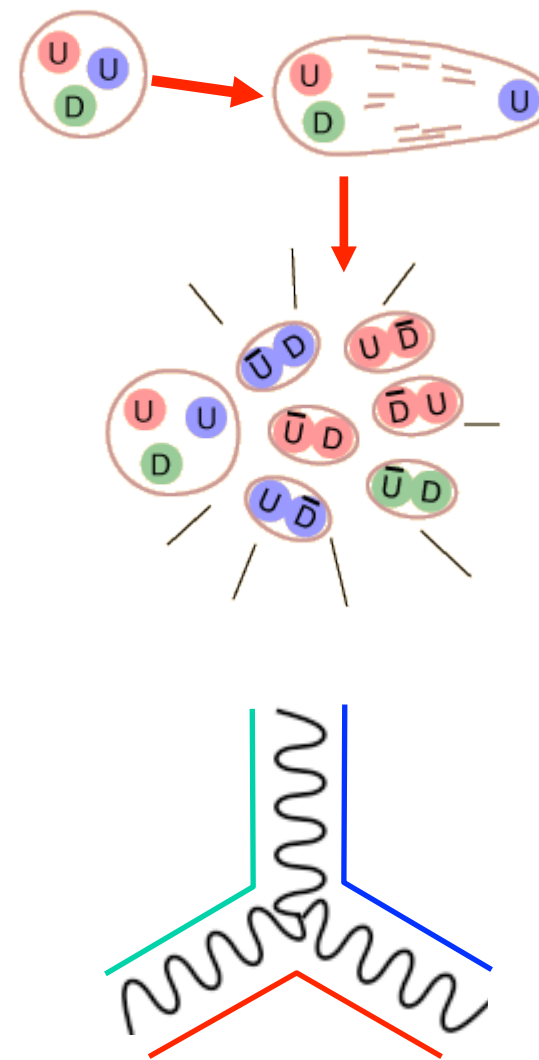



Running di α_s

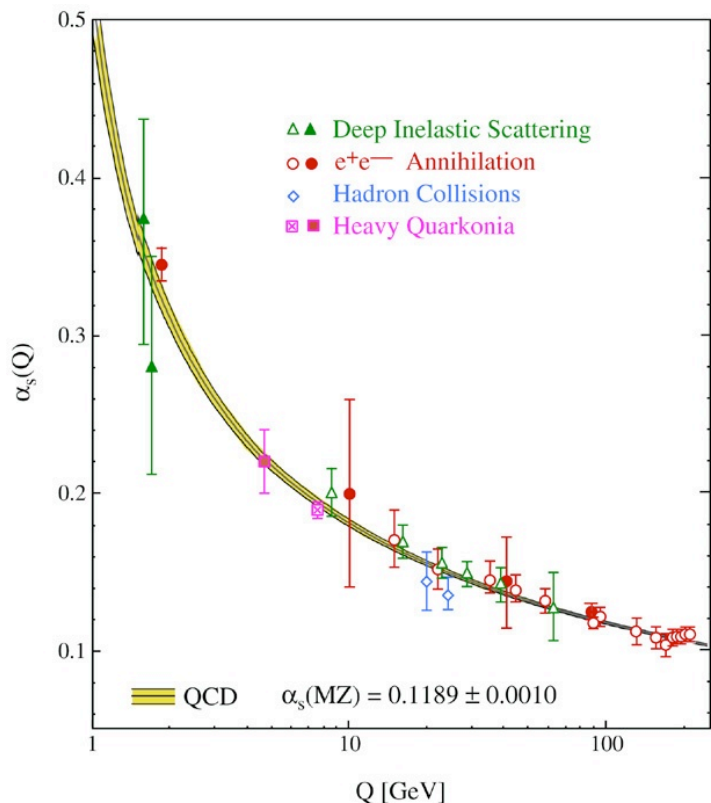

$$\mu \frac{\partial \alpha_s}{\partial \mu} = 2\beta(\alpha_s) = -\frac{\beta_0}{2\pi} \alpha_s^2 - \frac{\beta_1}{4\pi^2} \alpha_s^3 - \frac{\beta_2}{64\pi^3} \alpha_s^4 - \dots,$$

$$\beta_0 = 11 - \frac{2}{3} n_f,$$

$$\beta_1 = 51 - \frac{19}{3} n_f,$$

$$\beta_2 = 2857 - \frac{5033}{9} n_f + \frac{325}{27} n_f^2;$$

$$\alpha_s(\mu) = \frac{4\pi}{\beta_0 \ln(\mu^2/\Lambda^2)} \left[1 - \frac{2\beta_1}{\beta_0^2} \frac{\ln[\ln(\mu^2/\Lambda^2)]}{\ln(\mu^2/\Lambda^2)} + \frac{4\beta_1^2}{\beta_0^4 \ln^2(\mu^2/\Lambda^2)} \right. \\ \left. \times \left(\left(\ln[\ln(\mu^2/\Lambda^2)] - \frac{1}{2} \right)^2 + \frac{\beta_2 \beta_0}{8\beta_1^2} - \frac{5}{4} \right) \right].$$

L'intensità di α_s cresce con la scala di energia, mentre α_{em} decresce (gauge non abeliana!)

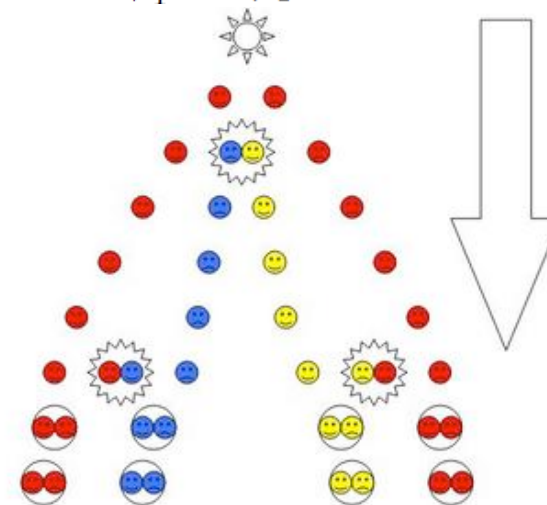
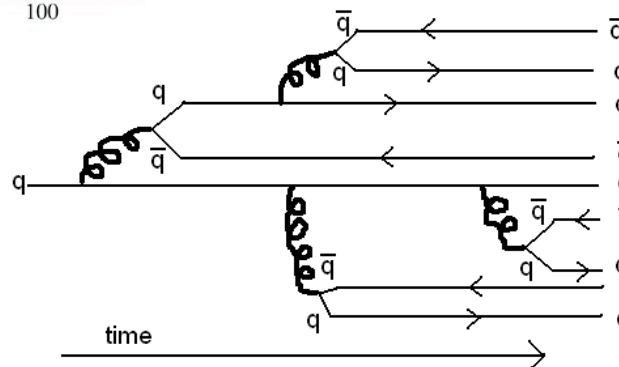



I quark e i jet



- I quark non possono essere osservati come **particelle libere**, ma solo nei loro stati legati (confinamento)
- La produzione di quark di alta energia si manifesta con gruppi di particelle ($E=mc^2$) detti jet che contengono i prodotti della **frammentazione** dei quark

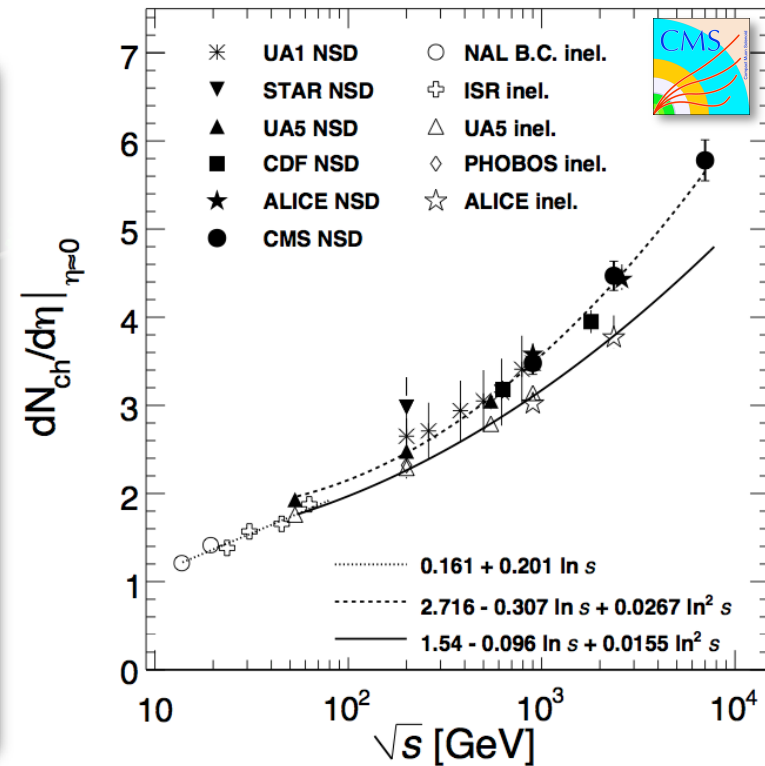
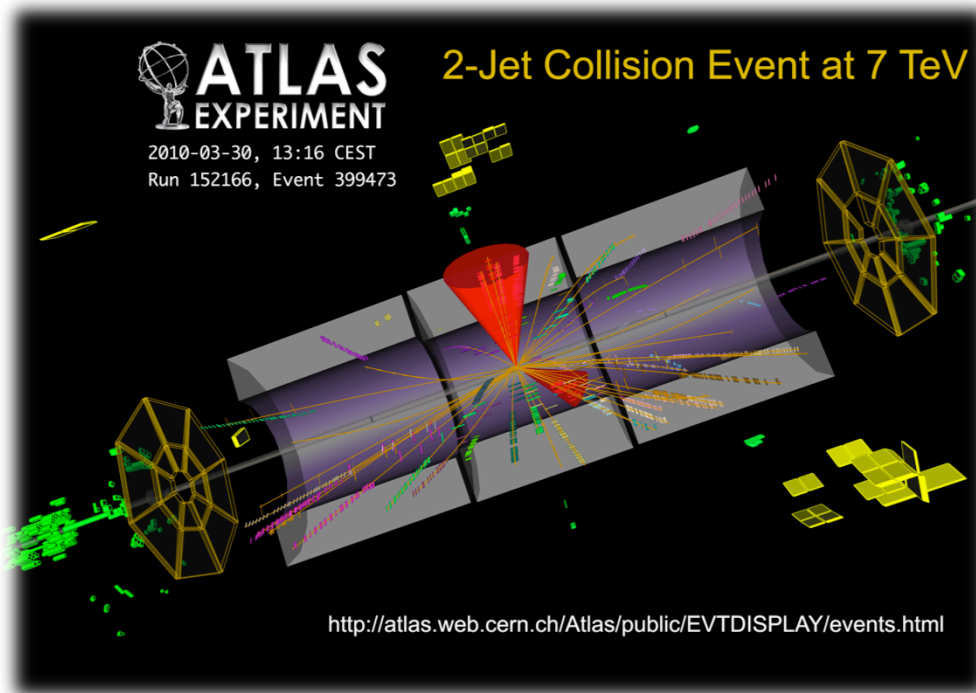



Il decadimento β e i quark



- Il decadimento β è simile ad altri decadimenti **deboli** di mesoni e barioni e del muone, ed è dovuto ad un processo che interessa un singolo quark
- La debolezza dell'interazione è dovuta alla bassa probabilità di emettere una **particella W** molto pesante del fotone che ha invece massa nulla

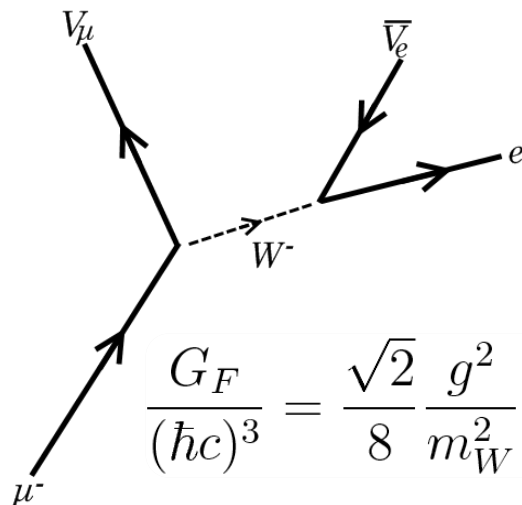
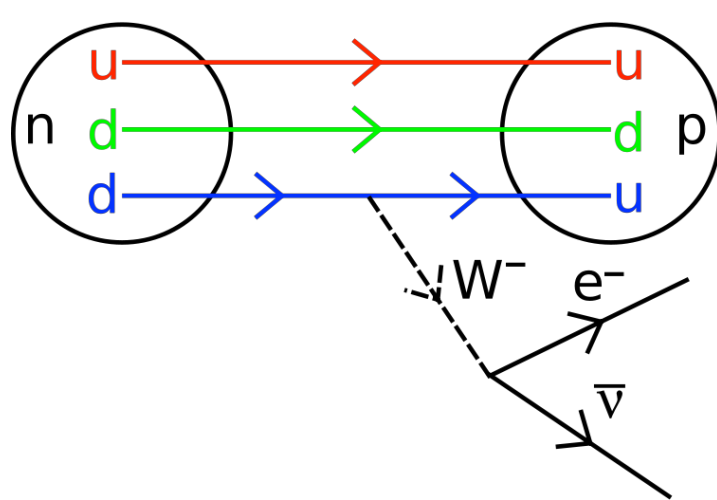

$$\frac{G_F}{(\hbar c)^3} = \frac{\sqrt{2}}{8} \frac{g^2}{m_W^2} = 1.6637(1) \times 10^{-5} \text{GeV}^{-2}$$



Deep inelastic scattering



- La struttura interna del protone può essere studiata con delle sonde che hanno **energia** e **potere risolutivo** sufficiente a penetrarne la struttura interna
- I risultati delle misure confermano il modello a quark
- E trovano una struttura interna molto complessa, piena di gluoni e quark **virtuali**

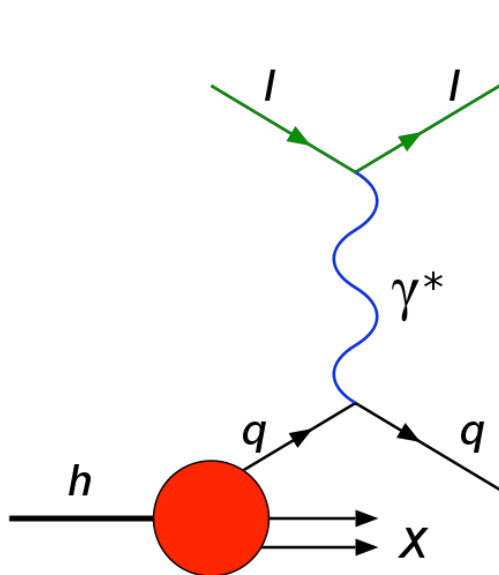

$$\lambda = \frac{hc}{E}$$

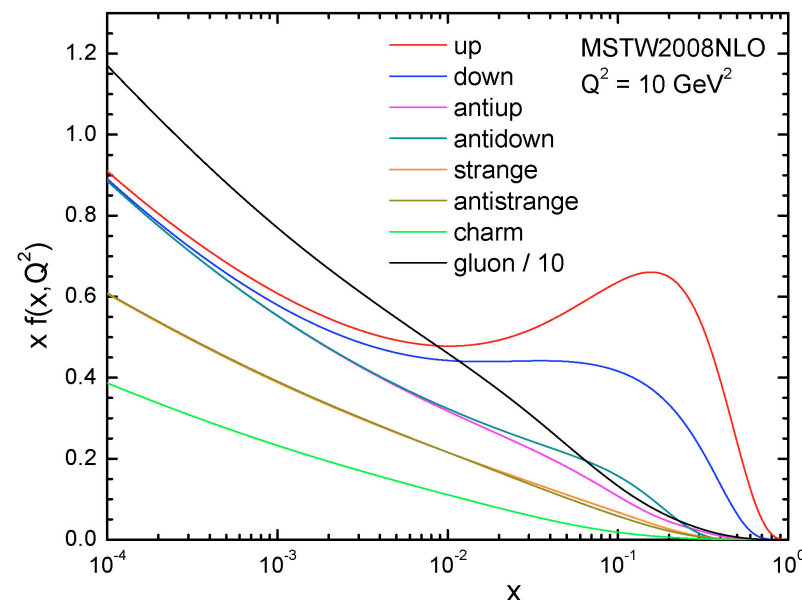
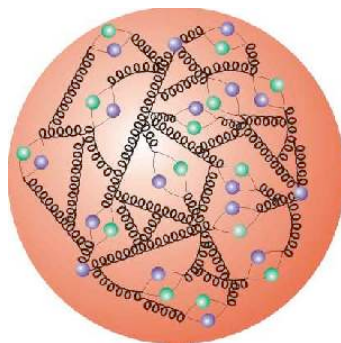

Parton Distribution Functions



Il meccanismo GIM



- Glashow, Iliopoulos e Maiani nel 1970 cercarono di spiegare l'assenza di alcuni meccanismi di decadimento attraverso la presenza di un quarto quark (charm)
- Ad esempio:

$$\frac{\Gamma(K_L \rightarrow \mu^+ \mu^-)}{\Gamma(K_L \rightarrow X)} = 6.87 \times 10^{-9}$$

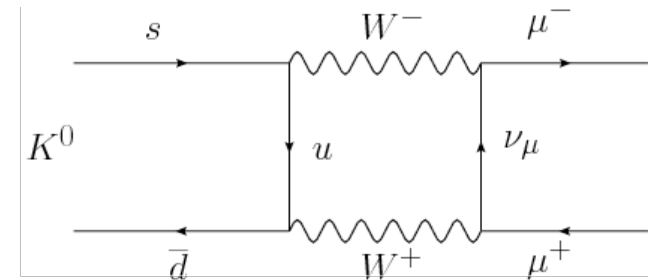

$$J^\mu(x) = \bar{u}(x)\gamma^\mu(1 - \gamma_5)(\cos \theta_C d(x) + \sin \theta_C s(x)) + \bar{c}(x)\gamma^\mu(1 - \gamma_5)(-\sin \theta_C d(x) + \cos \theta_C s(x))$$

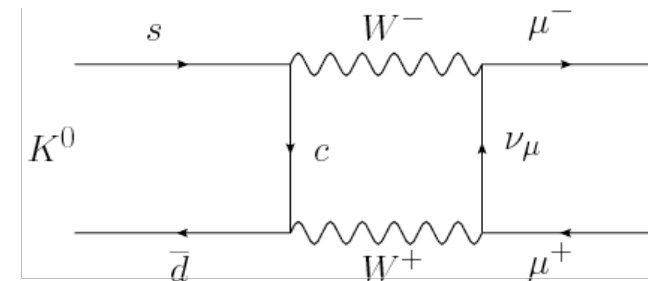



Il quark charm

- La scoperta del quark charm seguì nel 1974 la previsione del 1970 da parte di **Richter** (SLAC, e^+e^-) e **Ting** (BNL,) della particella J/Ψ , mesone fatto da una coppia di quark e antiquark charm
- Le particelle elementari formavano **due famiglie** di **quark** e **leptoni**

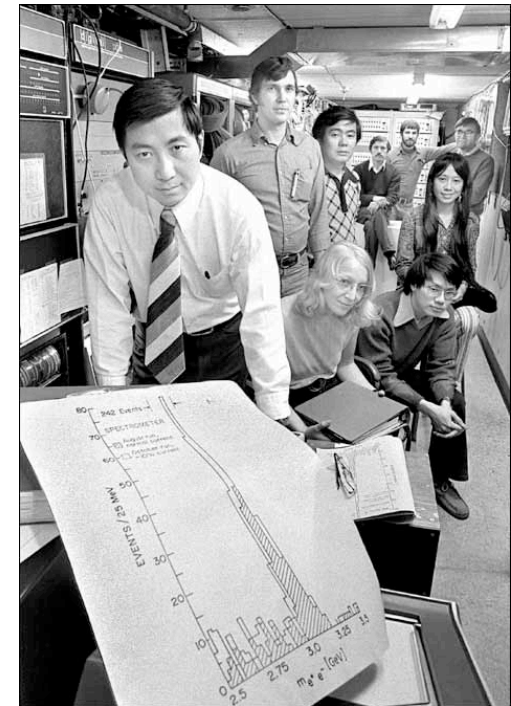
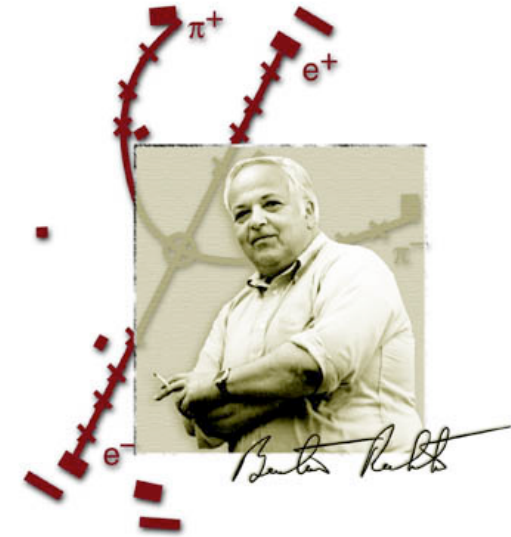
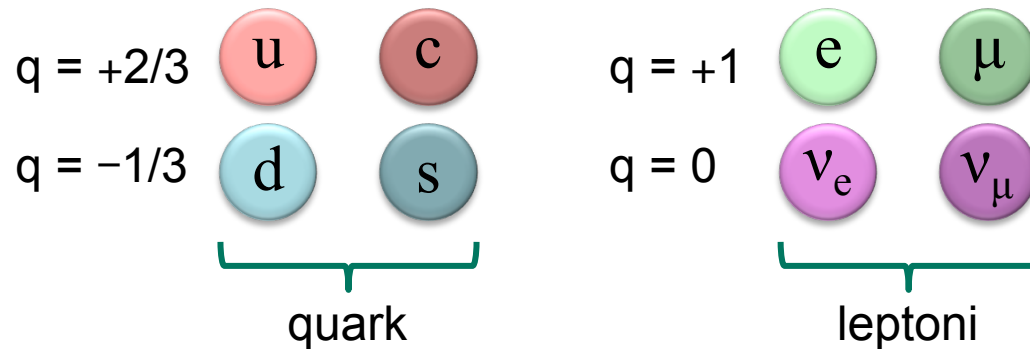



La terza famiglia



- La terza famiglia di quark è necessaria per spiegare l'asimmetria tra materia ed antimateria, ingrediente necessario a spiegare l'evoluzione dell'universo
- Ipotezzata da Kobayashi e Maskawa
 - 1975: scoperta del leptone tau a SLAC in collisioni elettrone-positrone
 - 1977: scoperta del quark b (mesone Y) in collisioni di protoni su bersaglio fisso
 - 1991: il LEP prova indirettamente l'esistenza di un terzo neutrino in collisioni elettrone-positrone
 - 1995: il Tevatron scopre il quark top in collisione protone-antiprotone

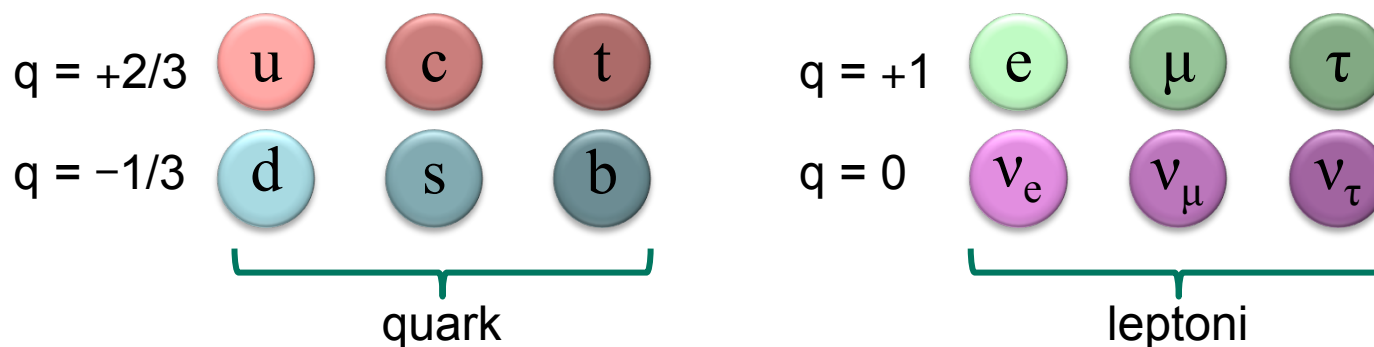
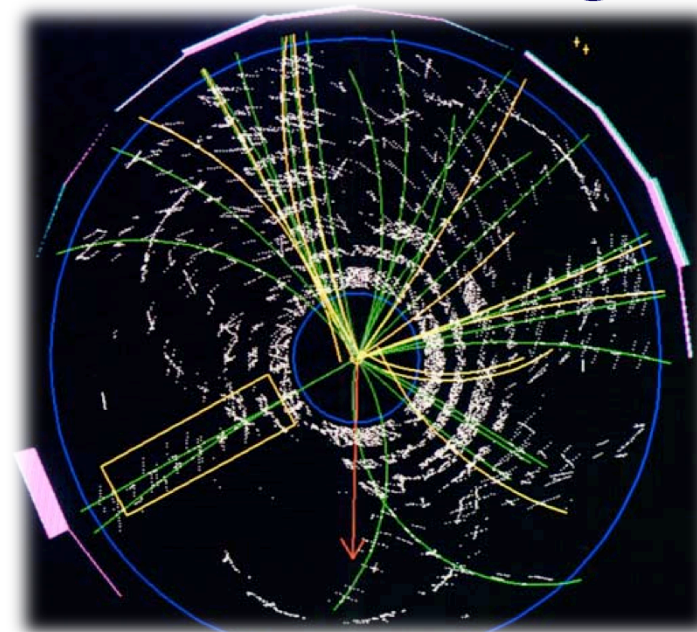



Il mixing tra i quark



- I decadimento deboli possono avvenire tra quark di tipo (“sapore”) diverso con l’emissione di una particella W
- Le transizioni hanno però diversa intensità, che viene misurata da una matrice (complessa) detta di Cabibbo-Kobayashi-Maskawa
- Una fase ineliminabile della matrice spiega l’asimmetria tra materia ed antimateria (violazione di CP) necessaria per spiegare l’estinzione dell’antimateria nell’universo attuale

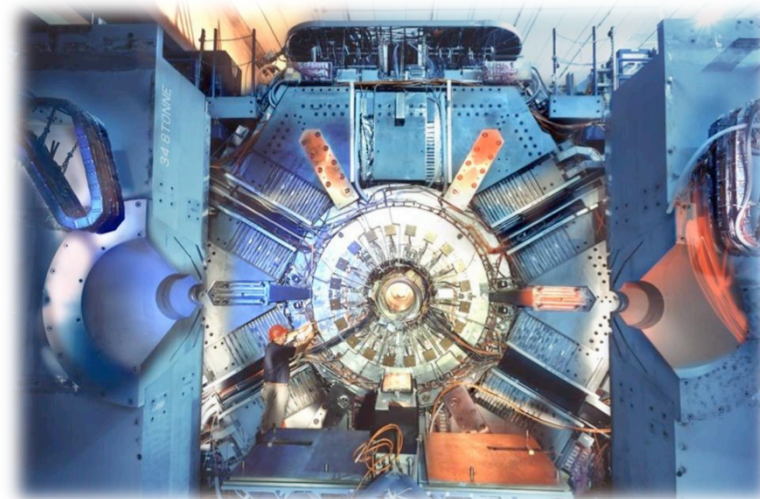
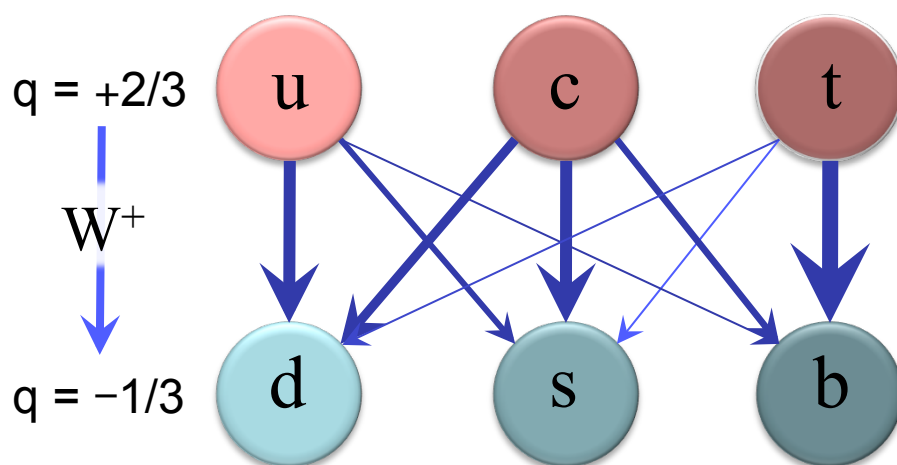



Il Modello Standard Elettrodebole

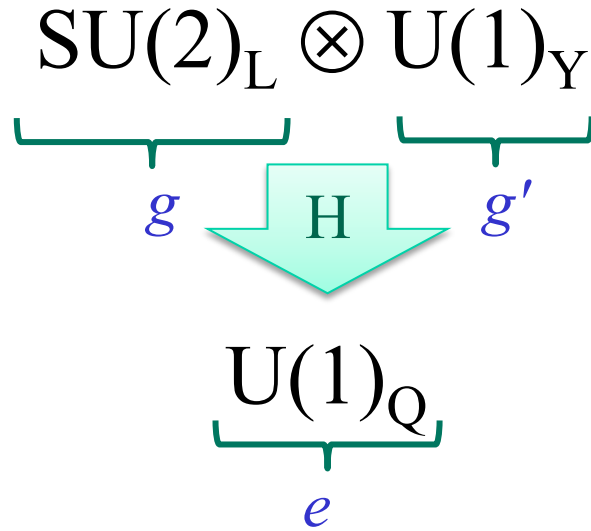

$$Q = T_3 + Y/2, \quad \tan\theta_W = g'/g$$

$$e = g \sin\theta_W$$

- Doppietti leptoni (L) (ν_L, l^-_L): $Y = -1$
- Doppietti quark (u, d): $Y = 1/3$
- Singoletti leptoni (R) l^-_R : $Y = -2$
- Singoletti quark (R) q_R : $Y = 4/3, -2/3$

Three Generations of Matter (Fermions)

	I	II	III	
mass→	2.4 MeV	1.27 GeV	171.2 GeV	0
charge→	$2/3$	$2/3$	$2/3$	0
spin→	$1/2$	$1/2$	$1/2$	1
name→	u up	c charm	t top	γ photon
	4.8 MeV	104 MeV	4.2 GeV	0
	$-1/3$	$-1/3$	$-1/3$	0
Quarks	$1/2$	$1/2$	$1/2$	1
	d down	s strange	b bottom	g gluon
	<2.2 eV	<0.17 MeV	<15.5 MeV	91.2 GeV
	0	0	0	0
	$1/2$	$1/2$	$1/2$	1
	ν_e electron neutrino	ν_μ muon neutrino	ν_τ tau neutrino	Z⁰ weak force
	0.511 MeV	105.7 MeV	1.777 GeV	80.4 GeV
	-1	-1	-1	± 1
Leptons	$1/2$	$1/2$	$1/2$	1
	e electron	μ muon	τ tau	W[±] weak force

Bosons (Forces)

$$M_Z = \sqrt{g^2 + g'^2} \frac{\nu}{2} = \frac{M_W}{\cos\theta_W}$$

$$\sin^2\theta_W = 1 - \frac{M_W^2}{M_Z^2}$$



Corrente carica



- Coinvolge solo la componente left-handed delle particelle
 - Violazione massimale della parità nei decadimenti β

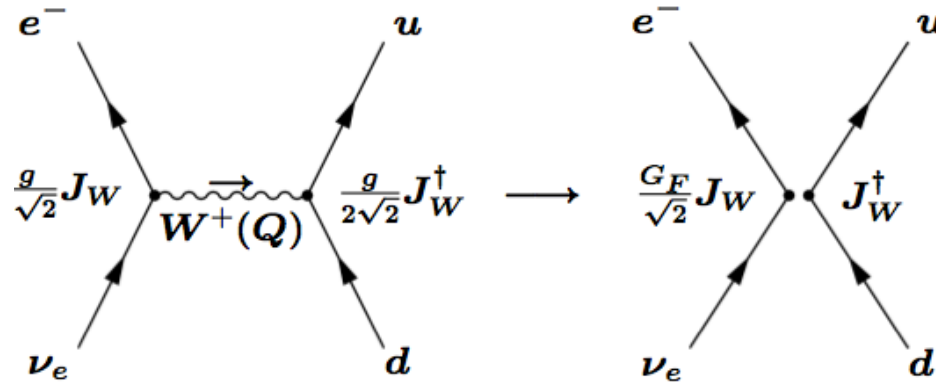
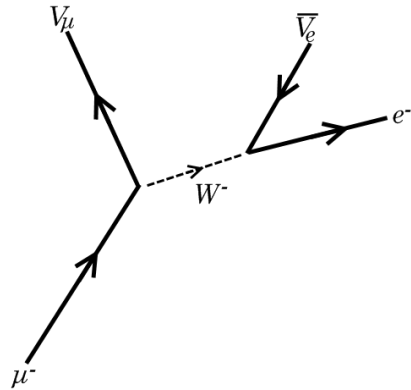

$$\mathcal{L} = -\frac{g}{2\sqrt{2}} \left(J_W^\mu W_\mu^- + J_W^{\mu\dagger} W_\mu^+ \right)$$

$$\frac{G_F}{(\hbar c)^3} = \frac{\sqrt{2}}{8} \frac{g^2}{m_W^2} = 1.6637(1) \times 10^{-5} \text{GeV}^{-2}$$

$$J_W^{\mu\dagger} = \sum_{m=1}^F [\bar{\nu}_m^0 \gamma^\mu (1 - \gamma^5) e_m^0 + \bar{u}_m^0 \gamma^\mu (1 - \gamma^5) d_m^0]$$



Vertici di Feynman nello SM



- Corrente neutra:

$$\mathcal{L} = -\frac{\sqrt{g^2 + g'^2}}{2} J_Z^\mu (-\sin \theta_W B_\mu + \cos \theta_W W_\mu^3) = -\frac{g}{2 \cos \theta_W} J_Z^\mu Z_\mu$$

$$J_Z^\mu = \sum_m [\bar{u}_{mL}^0 \gamma^\mu u_{mL}^0 - \bar{d}_{mL}^0 \gamma^\mu d_{mL}^0 + \bar{\nu}_{mL}^0 \gamma^\mu \nu_{mL}^0 - \bar{e}_{mL}^0 \gamma^\mu e_{mL}^0]$$

$$- 2 \sin^2 \theta_W J_Q^\mu$$

$$= \sum_m [\bar{u}_{mL} \gamma^\mu u_{mL} - \bar{d}_{mL} \gamma^\mu d_{mL} + \bar{\nu}_{mL} \gamma^\mu \nu_{mL} - \bar{e}_{mL} \gamma^\mu e_{mL}]$$

$$- 2 \sin^2 \theta_W J_Q^\mu.$$

$$g_V^i \equiv t_{3L}(i) - 2q_i \sin^2 \theta_W ,$$

$$g_A^i \equiv t_{3L}(i) ,$$

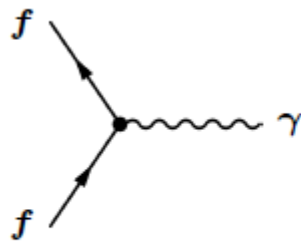

$$-ieq_f \gamma^\mu$$

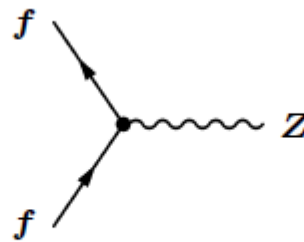

$$-i \frac{g}{2 \cos \theta_W} \gamma^\mu (g_V^f - g_A^f \gamma^5)$$

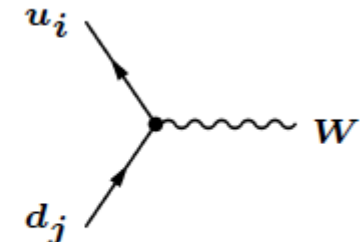

$$-i \frac{g}{2\sqrt{2}} \gamma^\mu (1 - \gamma^5) V_{qij}$$



Regole di Feynman

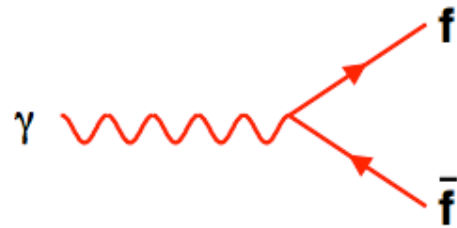

$$-ieQ\gamma_\mu$$

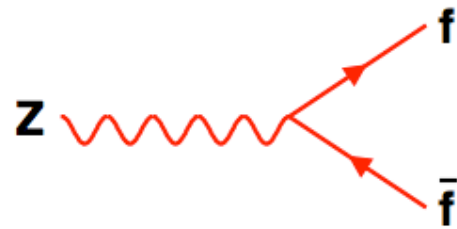

$$ie\gamma_\mu(g_v - g_a\gamma_5)\frac{1}{2\sin\theta_W\cos\theta_W}$$

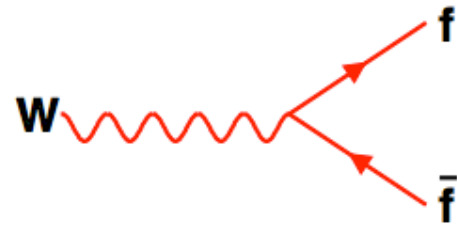

$$ie\gamma_\mu(1 - \gamma_5)\frac{1}{2\sqrt{2}\sin\theta_W}$$

$$g_a = T^3 = \pm\frac{1}{2}$$
$$g_v = (T^3 - 2Q\sin^2\theta_W) = \pm\frac{1}{2}(1 - 4|Q|\sin^2\theta_W)$$



Scoperta delle correnti neutre



- Gargamelle (CERN, 1973) misurò reazioni di un fascio di neutrini prodotti dal PS (protoni da 28 GeV)
- Segnatura: vertice di interazione senza produzione di leptoni

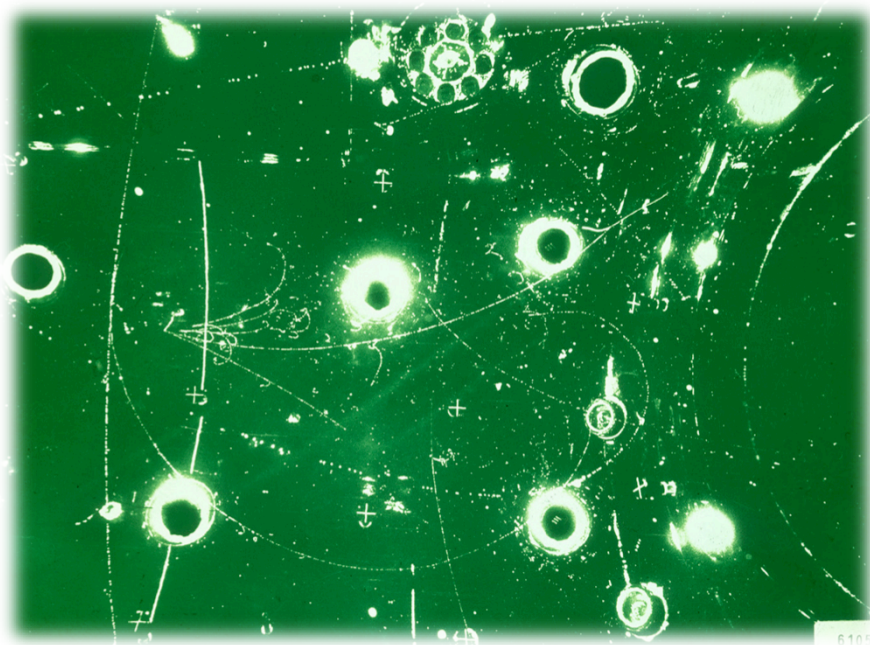

F. J. Hasert et al., Phys. Lett. B46, 138 (1973)





L'osservazione di W e Z



- UA1 e UA2 (CERN, 1983) osservarono la produzione diretta di W e Z in collisioni p - p^{bar} all'SPS a $450+450$ GeV

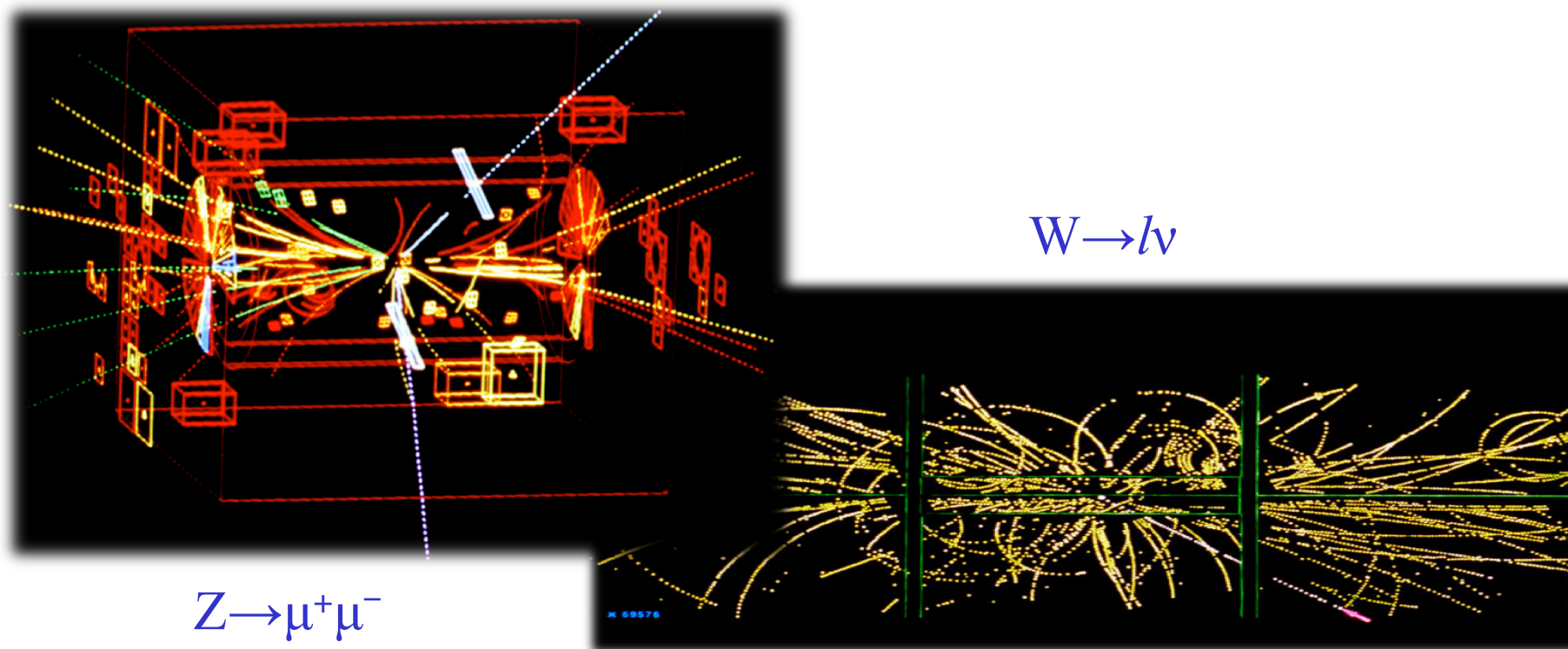



W e Z ad LHC (7 TeV)



$$W^+ \rightarrow \mu^+ \nu$$

$$Z \rightarrow e^+ e^-$$

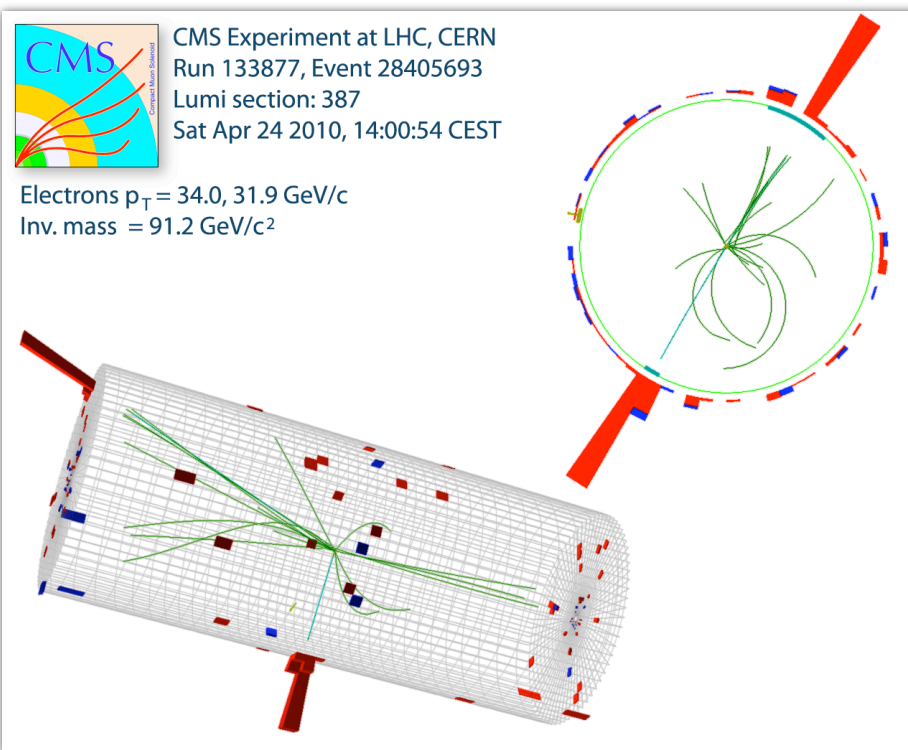
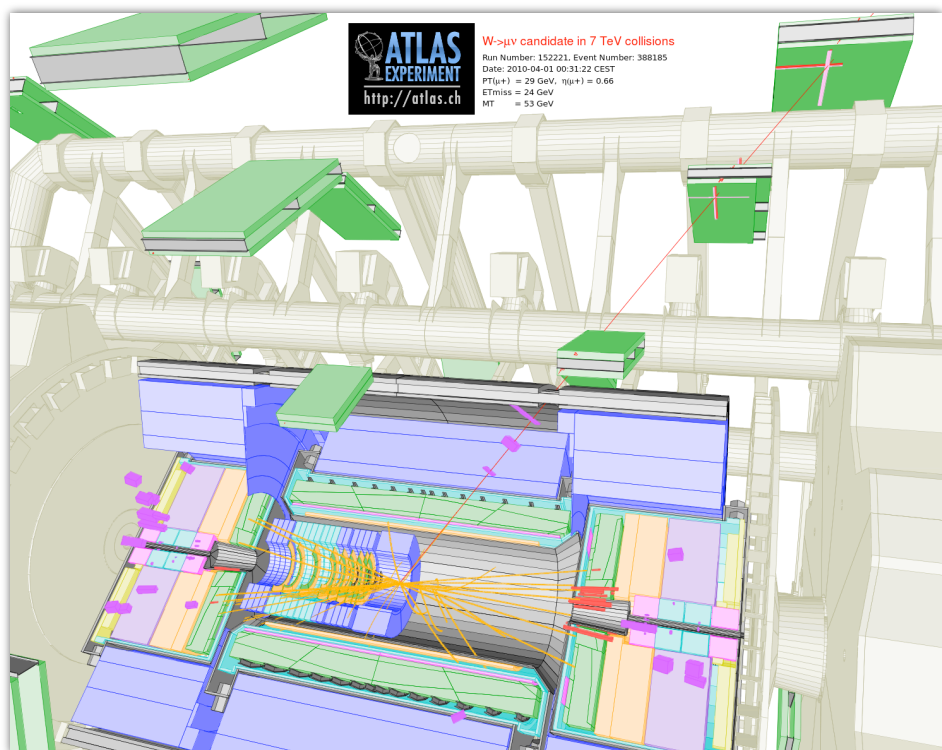



Verifiche del Modello Standard



- Misure di precisione al LEP e SLC in collisioni elettrone-positrone con energia (1989-2000)
- Energia di lavoro intorno alla massa della Z (risonanza!)
- Misure di precisione da milioni di decadimenti della Z

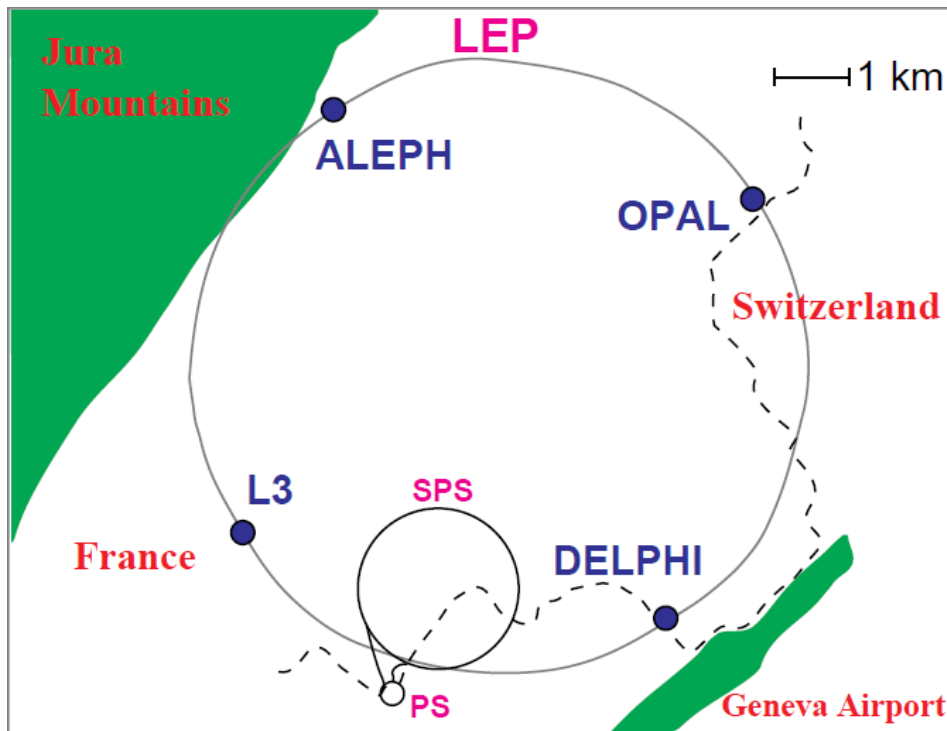

Year	Number of Events ($\times 10^3$)									
	$Z \rightarrow q\bar{q}$					$Z \rightarrow \ell^+\ell^-$				
	A	D	L	O	LEP	A	D	L	O	LEP
1990/91	433	357	416	454	1660	53	36	39	58	186
1992	633	697	678	733	2741	77	70	59	88	294
1993	630	682	646	649	2607	78	75	64	79	296
1994	1640	1310	1359	1601	5910	202	137	127	191	657
1995	735	659	526	659	2579	90	66	54	81	291
Total	4071	3705	3625	4096	15497	500	384	343	497	1724

$$m_Z = 91.1875 \pm 0.0021 \text{ GeV}$$

$$\Gamma_Z = 2.4952 \pm 0.0023 \text{ GeV}$$

$$\rho_\ell = 1.0050 \pm 0.0010$$

$$\sin^2 \theta_{\text{eff}}^{\text{lept}} = 0.23153 \pm 0.00016.$$



OPAL e L3

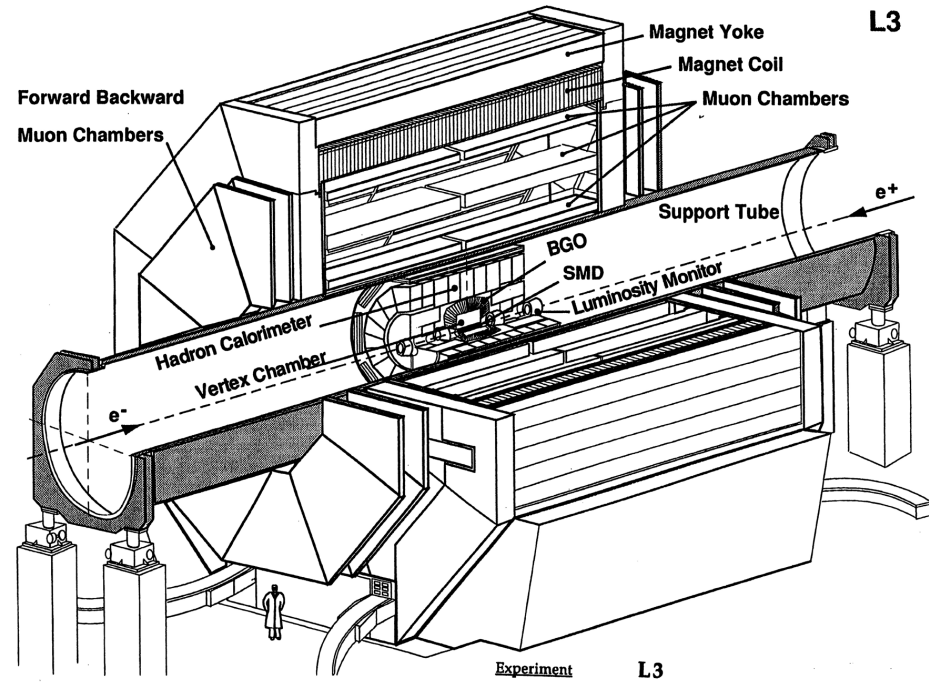
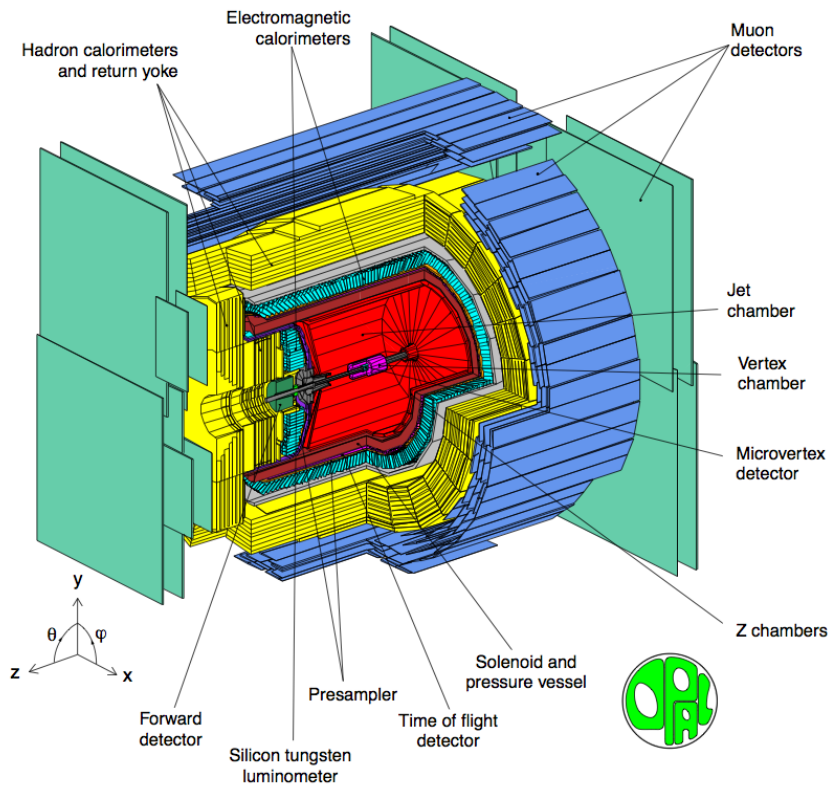



$$e^+e^- \rightarrow \mu^+\mu^-$$

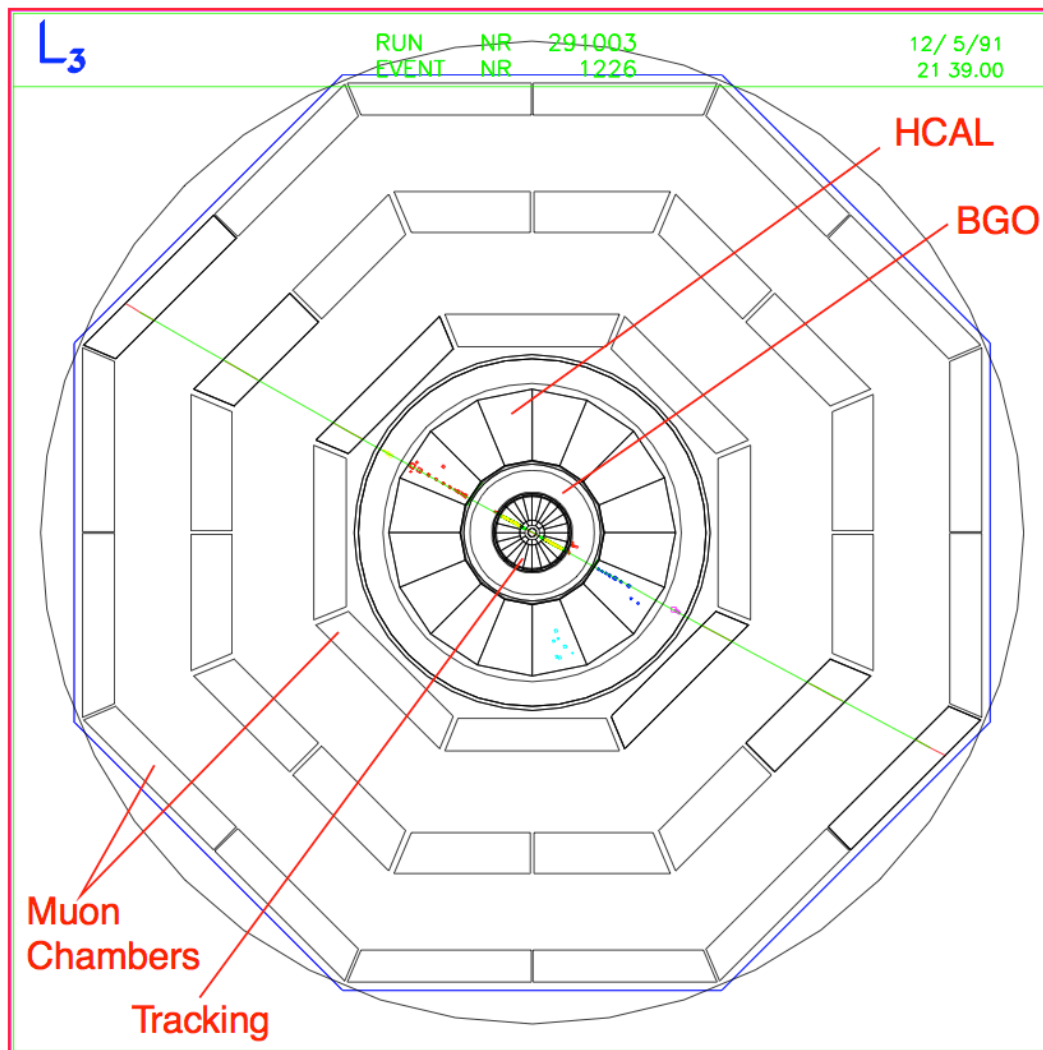



$$e^+e^- \rightarrow e^+e^-$$



Run:event 4093: 1150 Date 930527 Time 20751 Ctrk(N= 2 Sump= 92.4) Ecal(N= 9 SumE= 90.5) Hcal(N= 0 SumE= 0.0)
Ebeam 45.858 Evis 94.4 Emiss -3.1 Vtx (-0.05, 0.08, 0.36) Muon(N= 0) Sec Vtx(N= 0) Foot(N= 1 SumE= 0.0)
Bz=4.350 Thrust=0.9979 Aplan=0.0000 Oblat=0.0039 Spher=0.0001

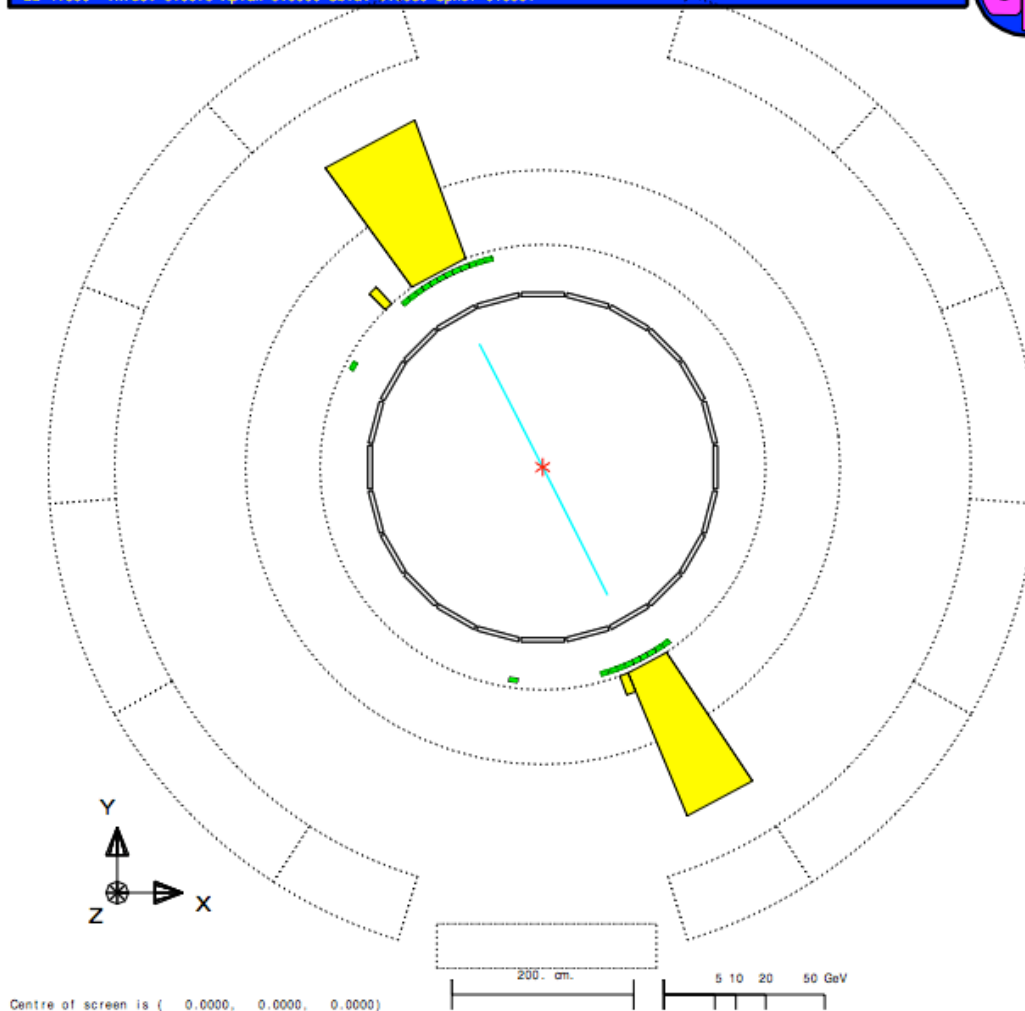



$$e^+e^- \rightarrow qq$$

```
Run:event 4093: 1000 Date 930527 Time 20716 Clrk(N= 39 Sump= 73.3) Ecal(N= 25 SunE= 32.6) Hcal(N=22 SunE= 22.6)
Ebeam 45.658 Evis 99.9 Emis -8.6 Vtx ( -0.07, 0.06, -0.80) Muon(N= 0) Sec Vtx(N= 3) Fdel(N= 0 SunE= 0.0)
Bz=-4.350 Thrust=0.9873 Aplan=0.0017 Obiat=-0.1248 Spher=0.0073
```

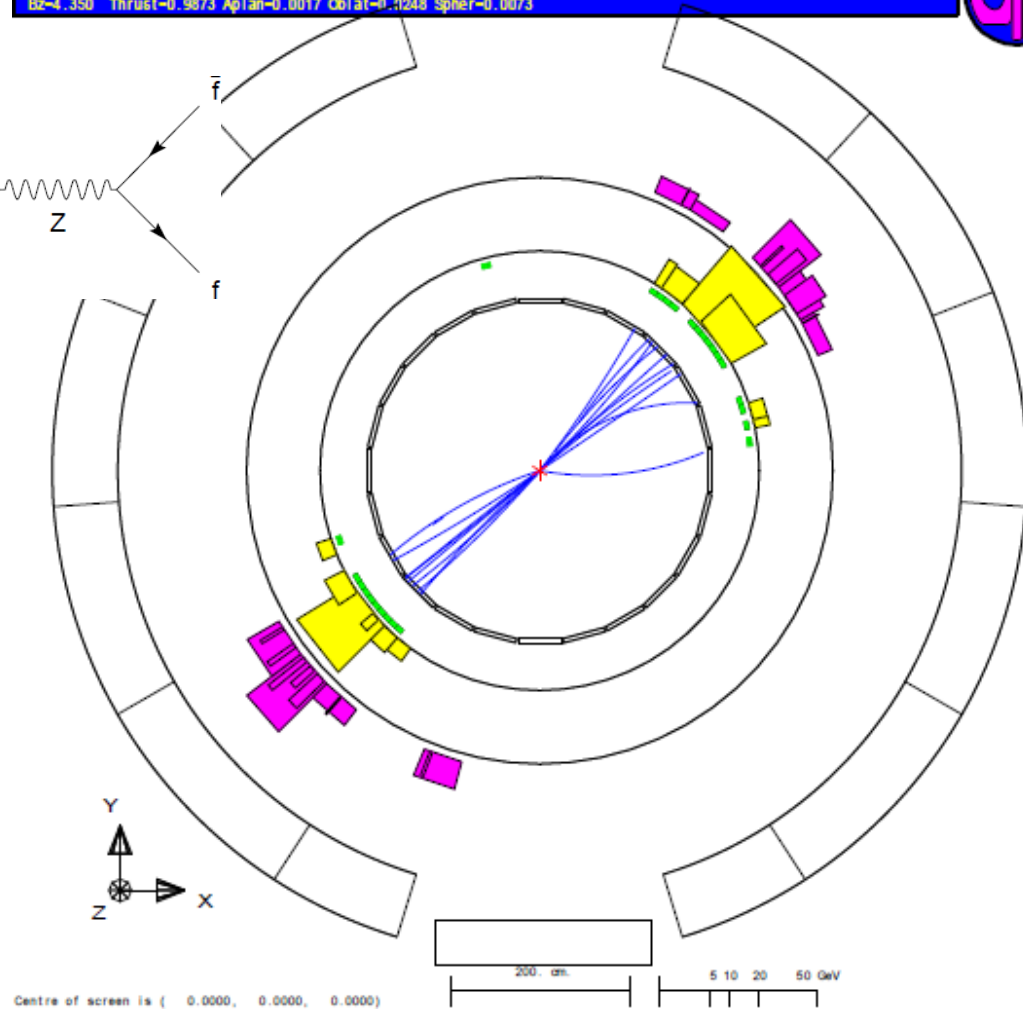
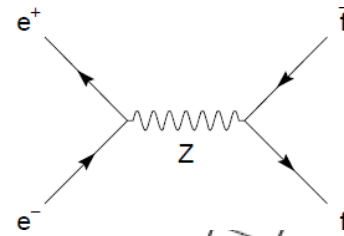
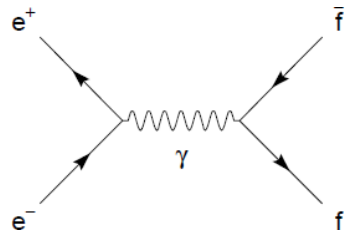



$$e^+e^- \rightarrow \tau^+\tau^-$$

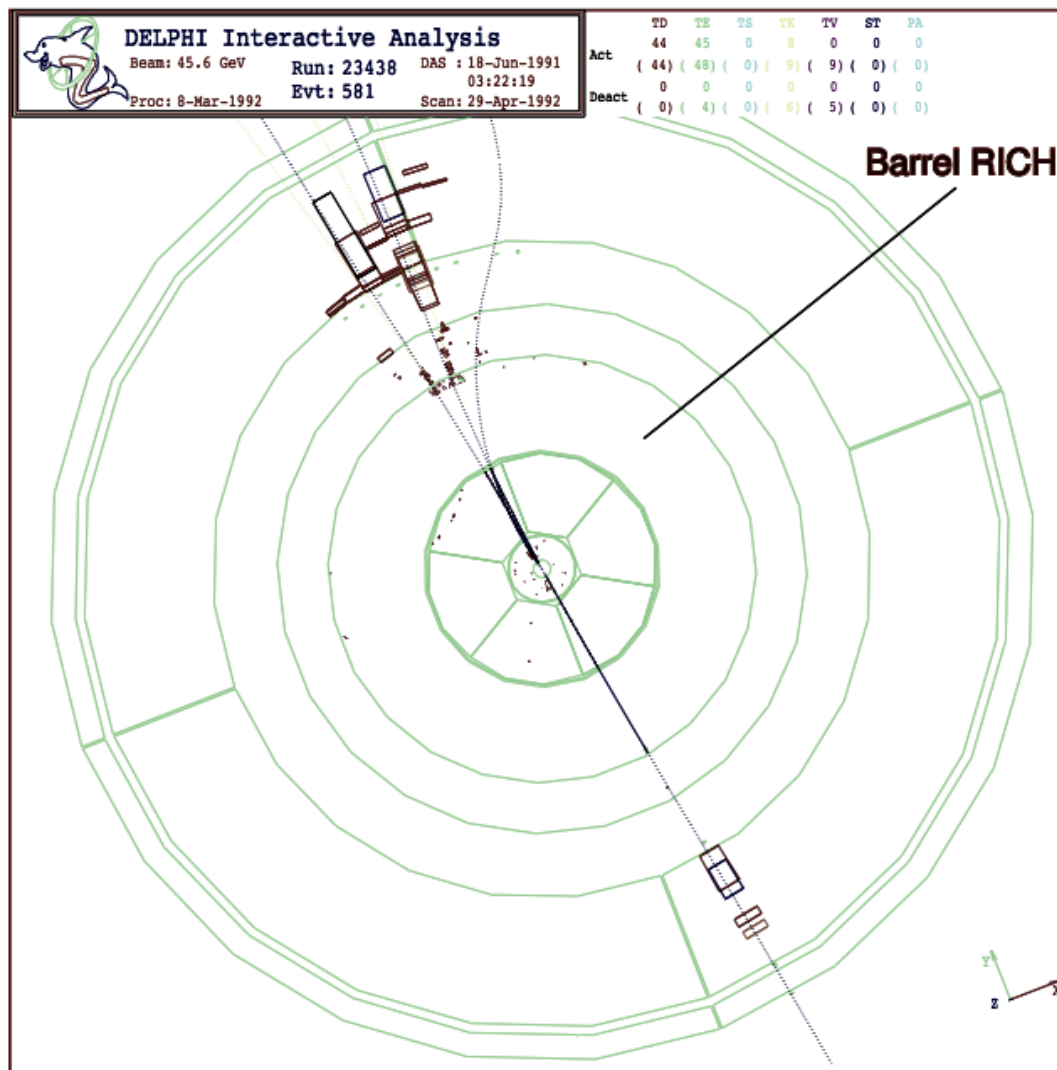



Selezione degli eventi



ALEPH

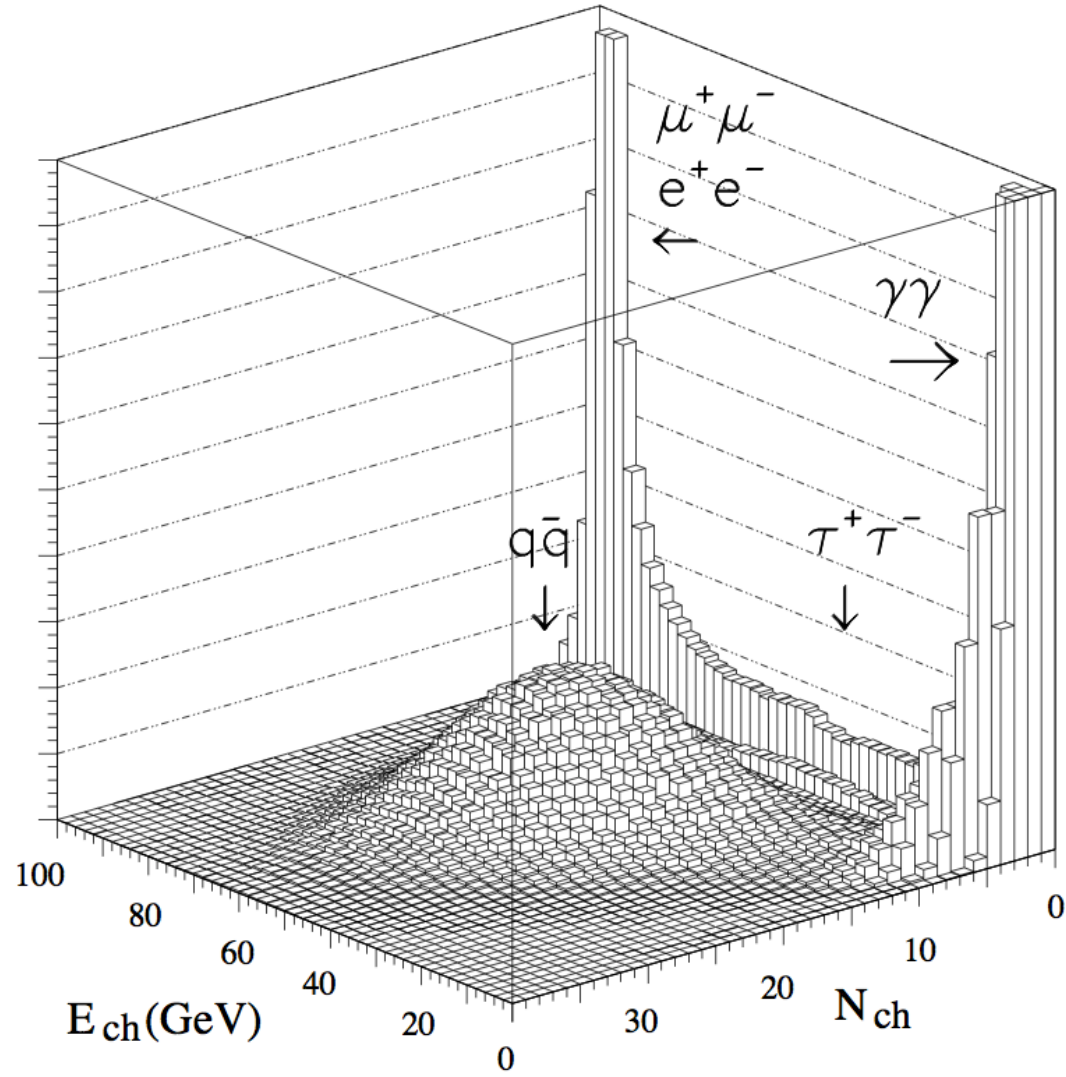



Line shape della Z

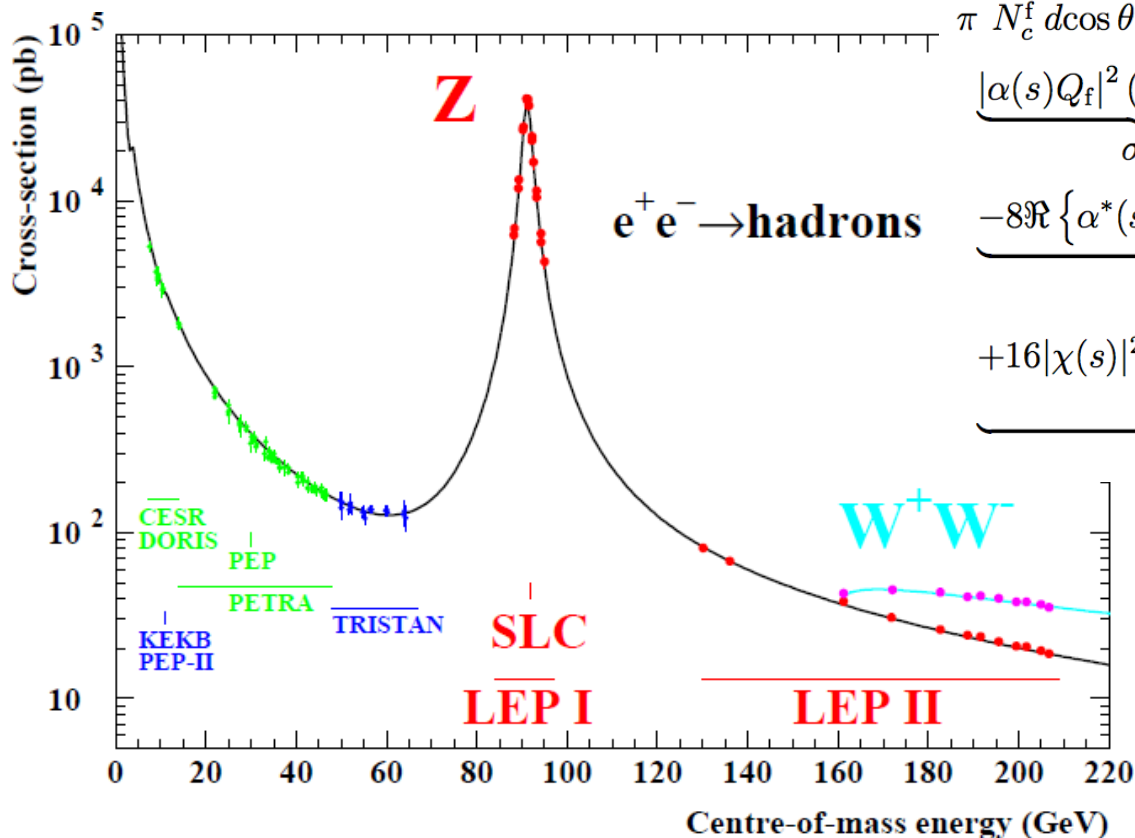

$$\frac{2s}{\pi} \frac{1}{N_c^f} \frac{d\sigma_{ew}}{d\cos\theta}(e^+e^- \rightarrow f\bar{f}) =$$

$$\underbrace{|\alpha(s)Q_f|^2 (1 + \cos^2\theta)}_{\sigma^\gamma}$$

$$\underbrace{-8\Re\left\{\alpha^*(s)Q_f\chi(s)\left[\mathcal{G}_{Ve}\mathcal{G}_{Vf}(1 + \cos^2\theta) + 2\mathcal{G}_{Ae}\mathcal{G}_{Af}\cos\theta\right]\right\}}_{\gamma\text{-Z interference}}$$

$$\underbrace{+16|\chi(s)|^2\left[|\mathcal{G}_{Ve}|^2 + |\mathcal{G}_{Ae}|^2\right]\left[|\mathcal{G}_{Vf}|^2 + |\mathcal{G}_{Af}|^2\right](1 + \cos^2\theta) + 8\Re\left\{\mathcal{G}_{Ve}\mathcal{G}_{Ae}^*\right\}\Re\left\{\mathcal{G}_{Vf}\mathcal{G}_{Af}^*\right\}\cos\theta}_{\sigma^Z}$$

Dove:

$$\chi(s) = \frac{G_F m_Z^2}{8\pi\sqrt{2}} \frac{s}{s - m_Z^2 + is\Gamma_Z/m_Z}$$

$$\mathcal{G}_{Vf} = \sqrt{\mathcal{R}_f} (T_3^f - 2Q_f \mathcal{K}_f \sin^2\theta_W)$$

$$\mathcal{G}_{Af} = \sqrt{\mathcal{R}_f} T_3^f.$$



Fattori di forma dovuti a correzioni di ordine superiore



Correzioni di ordine superiore



- Le correzioni radiative modificano le relazioni dello SM al tree level:

$$\rho_0 = \frac{m_W^2}{m_Z^2 \cos^2 \theta_W} = 1 \quad \rightarrow \quad \rho = 1 + \Delta\rho$$

$$\frac{g_{Vf}}{g_{Af}} = \Re \left(\frac{\mathcal{G}_{Vf}}{\mathcal{G}_{Af}} \right) = 1 - 4|Q_f| \sin^2 \theta_{\text{eff}}^f$$

$$\sin^2 \theta_{\text{eff}}^f \equiv \kappa_f \sin^2 \theta_W$$

$$g_{Vf} \equiv \sqrt{\rho_f} (T_3^f - 2Q_f \sin^2 \theta_{\text{eff}}^f)$$

$$g_{Af} \equiv \sqrt{\rho_f} T_3^f,$$

$$\Delta\rho_{\text{se}} = \frac{3G_F m_W^2}{8\sqrt{2}\pi^2} \left[\frac{m_t^2}{m_W^2} - \frac{\sin^2 \theta_W}{\cos^2 \theta_W} \left(\ln \frac{m_H^2}{m_W^2} - \frac{5}{6} \right) + \dots \right]$$

$$\Delta\kappa_{\text{se}} = \frac{3G_F m_W^2}{8\sqrt{2}\pi^2} \left[\frac{m_t^2 \cos^2 \theta_W}{m_W^2 \sin^2 \theta_W} - \frac{10}{9} \left(\ln \frac{m_H^2}{m_W^2} - \frac{5}{6} \right) + \dots \right] \quad (\text{per } m_H \gg m_W)$$

$$\rho_f \equiv \Re(\mathcal{R}_f) = 1 + \Delta\rho_{\text{se}} + \Delta\rho_f$$

$$\kappa_f \equiv \Re(\mathcal{K}_f) = 1 + \Delta\kappa_{\text{se}} + \Delta\kappa_f$$

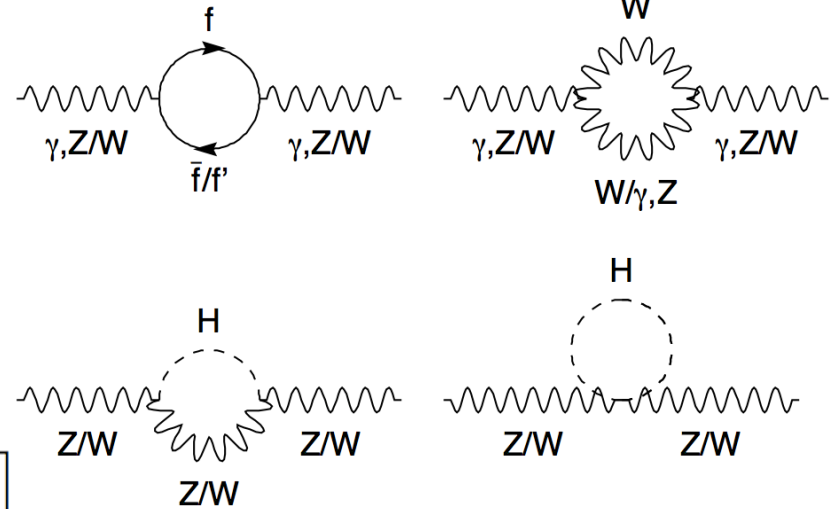



Correzioni a GF



- Dipendenza delle correzioni:
 - Quadratica da m_t
 - Logaritmica dai m_H

$$\cos^2 \theta_{\text{eff}}^f \sin^2 \theta_{\text{eff}}^f = \frac{\pi\alpha(0)}{\sqrt{2}m_Z^2 G_F} \frac{1}{1 - \Delta r^f} \quad \Delta r^f = \Delta\alpha + \Delta r_w^f$$

$$\alpha(s) = \frac{\alpha(0)}{1 - \Delta\alpha} \quad \Delta r_w^f = -\Delta\rho + \dots$$

$$\alpha(0) = 1/137.03599976(50) ; \alpha(M_Z) = 1/128.936(46)$$

$$m_W^2 = \frac{m_Z^2}{2} \left(1 + \sqrt{1 - 4 \frac{\pi\alpha}{\sqrt{2}G_F m_Z^2} \frac{1}{1 - \Delta r}} \right)$$



Correzioni per $e^+e^- \rightarrow bb$



- La produzione bb risente particolarmente dell'effetto del quark t

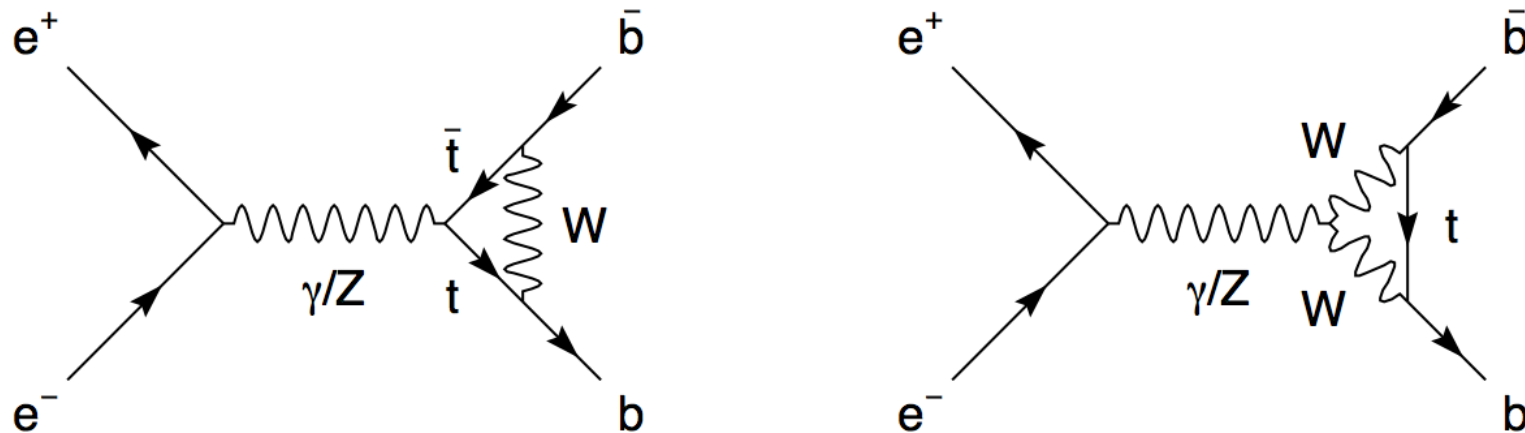

$$\Delta\kappa_b = \frac{G_F m_t^2}{4\sqrt{2}\pi^2} + \dots$$

$$\Delta\rho_b = -2\Delta\kappa_b + \dots$$



Correzioni radiative



- Radiazione di stati finale e iniziale distorce lo spettro della Z

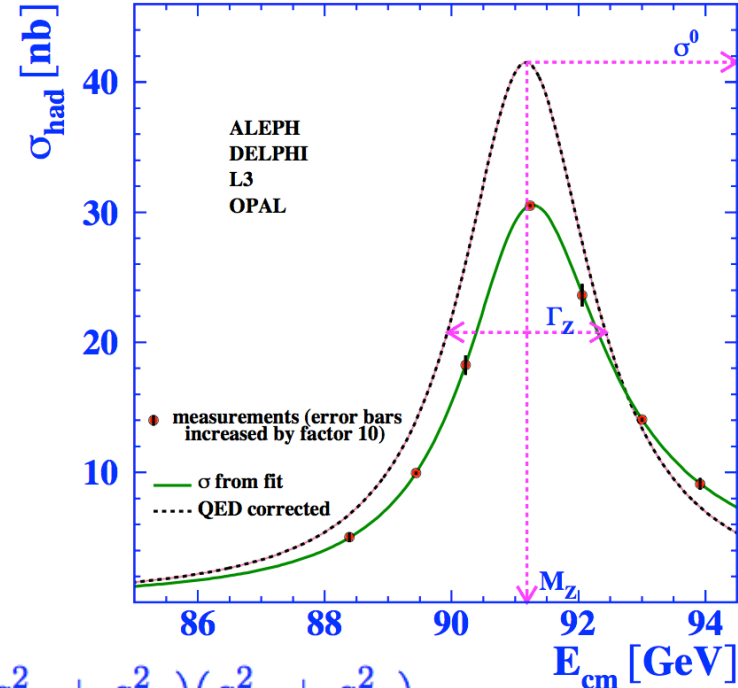
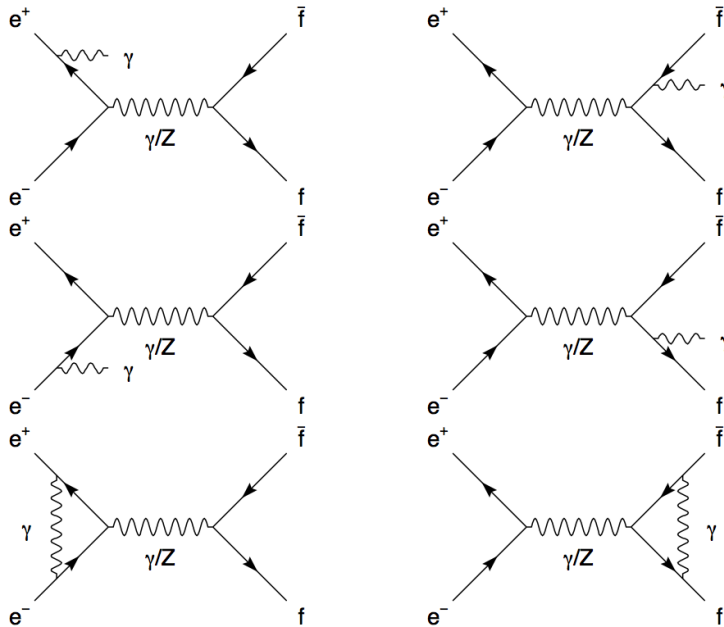

$$\sigma_{ff} \propto (g_{V_e}^2 + g_{A_e}^2)(g_{V_f}^2 + g_{A_f}^2)$$

$$\sigma(s) = \int_{4m_f^2/s}^1 dz H_{\text{QED}}^{\text{tot}}(z, s) \sigma_{\text{ew}}(zs)$$

$$\sigma_{ff}^Z = \sigma_{ff}^{\text{peak}} \frac{s\Gamma_Z^2}{(s - m_Z^2)^2 + s^2\Gamma_Z^2/m_Z^2}$$

$$\sigma_{ff}^{\text{peak}} = \frac{1}{R_{\text{QED}}} \sigma_{ff}^0 \quad \sigma_{ff}^0 = \frac{12\pi}{m_Z^2} \frac{\Gamma_{ee}\Gamma_{ff}}{\Gamma_Z^2} \quad R_e^0 \equiv \Gamma_{\text{had}}/\Gamma_{ee}, \quad R_u^0 \equiv \Gamma_{\text{had}}/\Gamma_{\mu\mu} \quad \text{and} \quad R_\tau^0 \equiv \Gamma_{\text{had}}/\Gamma_{\tau\tau}$$



Numero di neutrini leggeri



- Il numero di neutrini si ricava indirettamente dalla larghezza totale della Z e dalle larghezze

$$\Gamma_Z = \Gamma_{ee} + \Gamma_{\mu\mu} + \Gamma_{\tau\tau} + \Gamma_{\text{had}} + \Gamma_{\text{inv}}$$

$$R_{\text{inv}}^0 = N_\nu \left(\frac{\Gamma_{\nu\bar{\nu}}}{\Gamma_{\ell\ell}} \right)_{\text{SM}}$$

$$N_\nu = 2.9840 \pm 0.0082$$

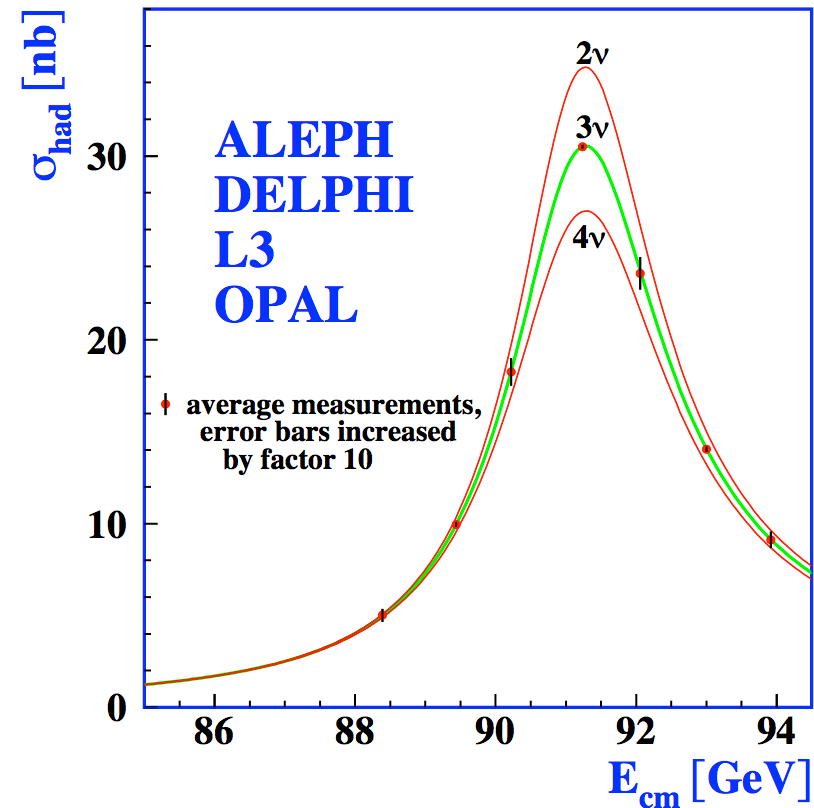



Asimmetria FB



- Misura della sezione d'urto differenziale in funzione di θ

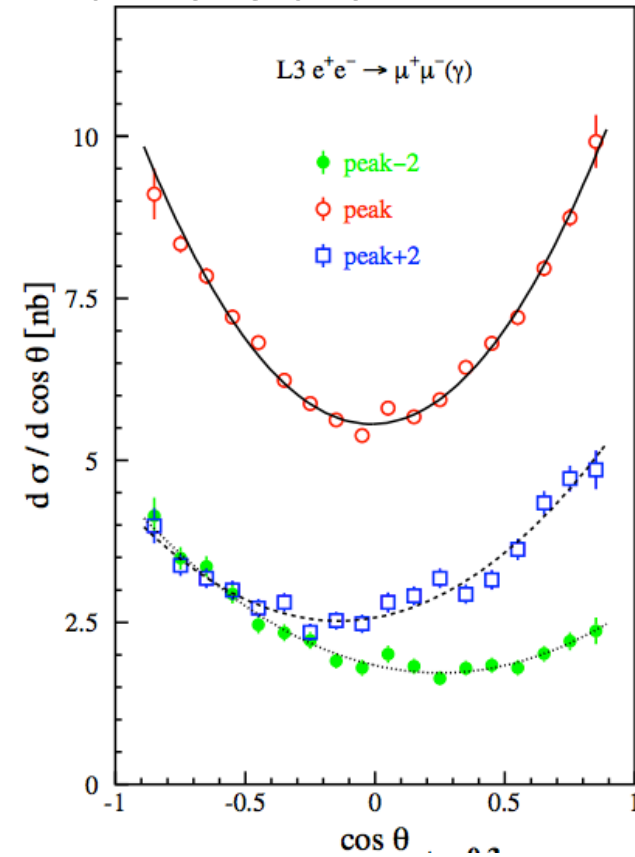
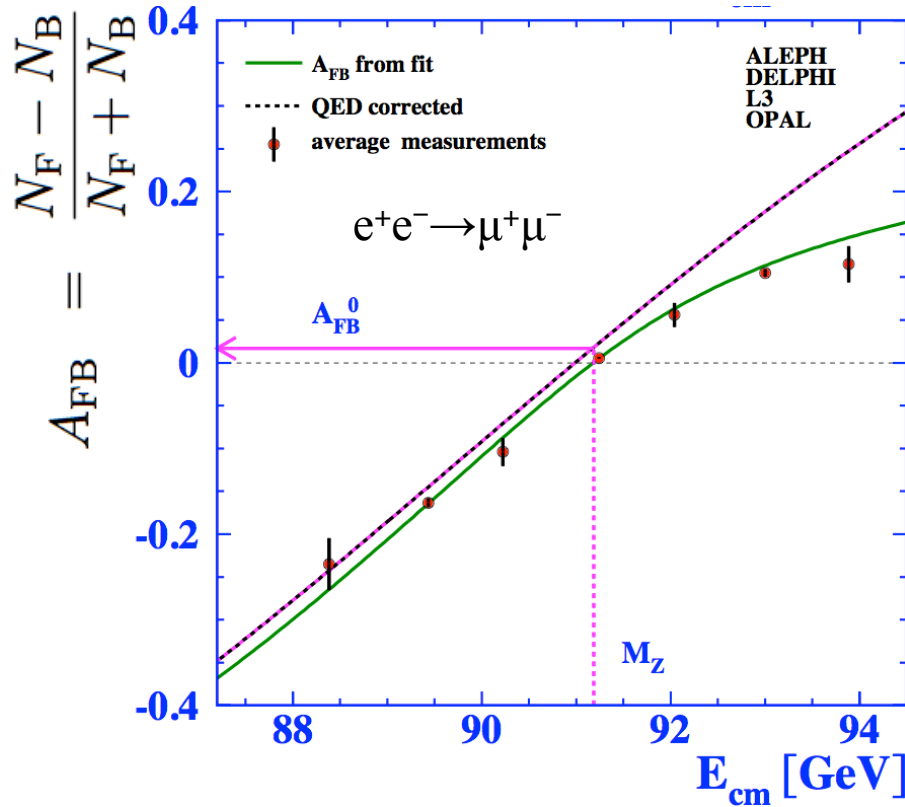

$$A_{FB}^{0,f} = \frac{3}{4} \frac{2g_{Ve}g_{Ae}}{g_{Ve}^2 + g_{Ae}^2} \frac{2g_{Vf}g_{Af}}{g_{Vf}^2 + g_{Af}^2} \equiv \frac{3}{4} \mathcal{A}_e \mathcal{A}_f \mathcal{A}_f = \frac{g_{Lf}^2 - g_{Rf}^2}{g_{Lf}^2 + g_{Rf}^2} = \frac{2g_{Vf}g_{Af}}{g_{Vf}^2 + g_{Af}^2} = 2 \frac{g_{Vf}/g_{Af}}{1 + (g_{Vf}/g_{Af})^2}$$



Fit a line-shape e asimmetria FB

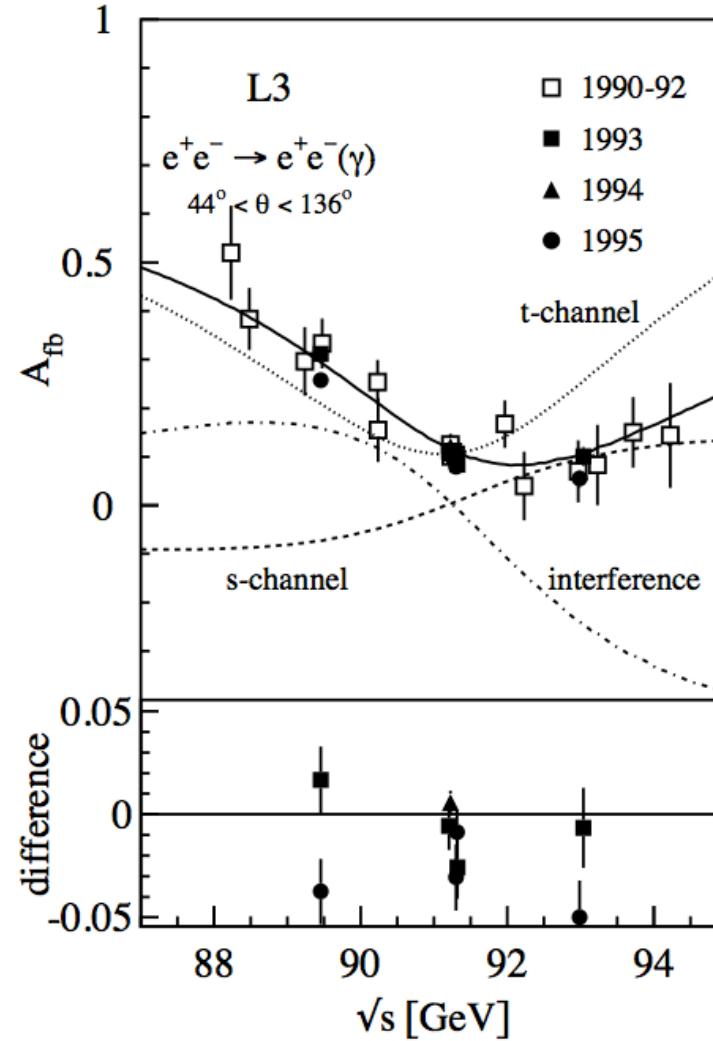
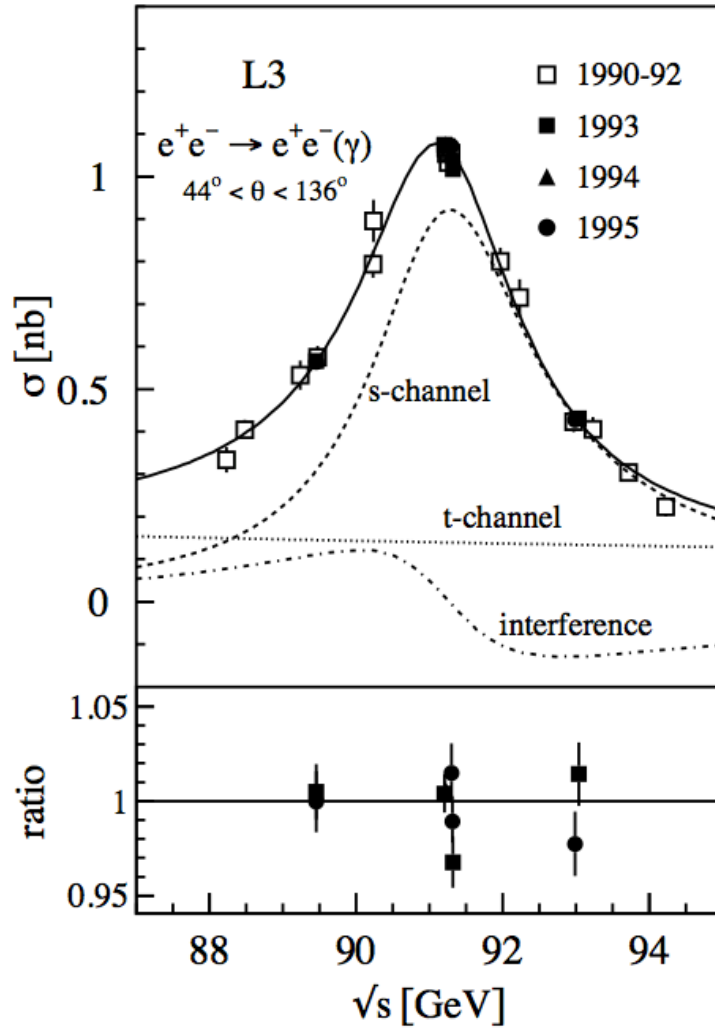



Universalità leptonica

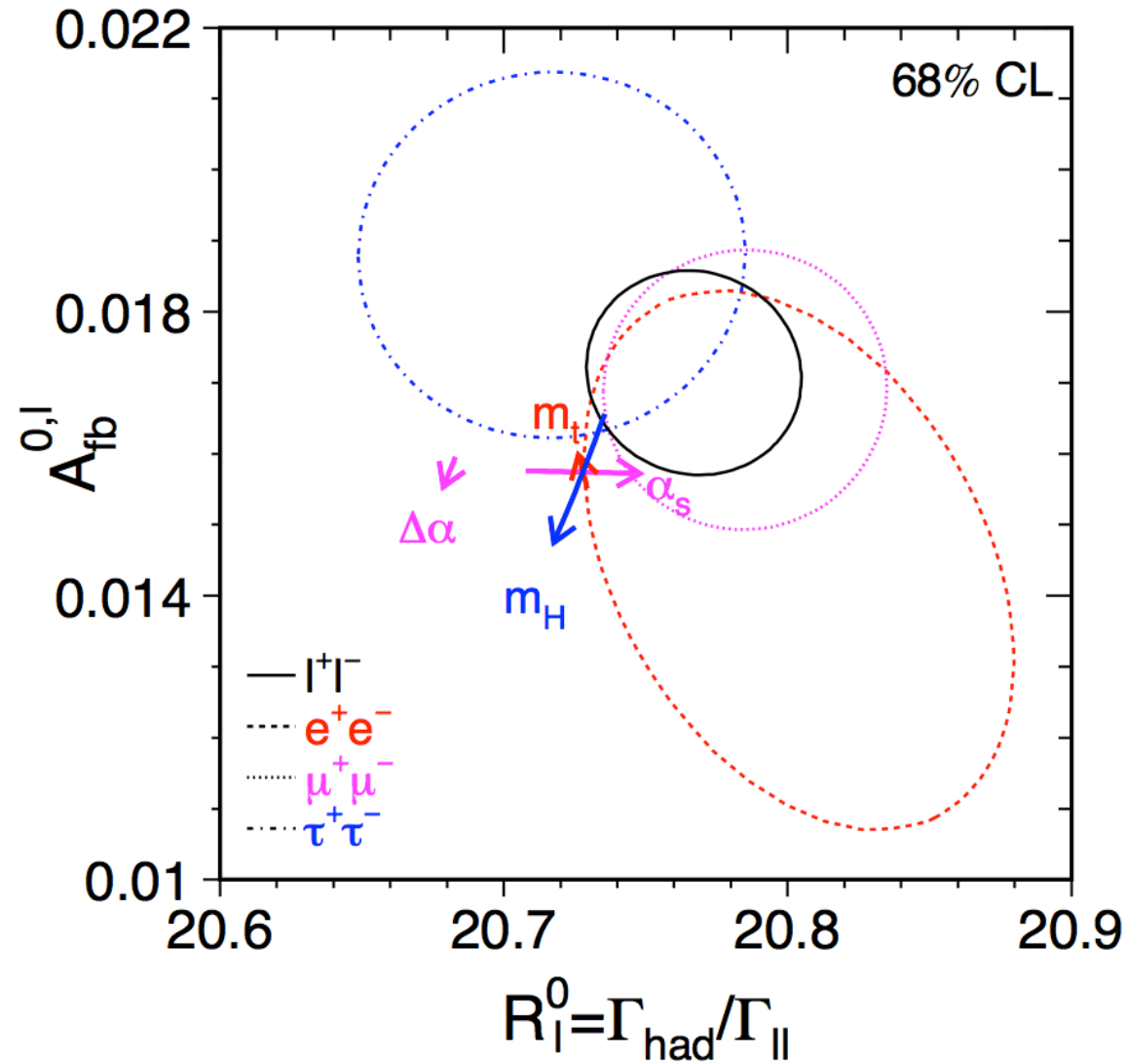



SLC/SLD a SLAC

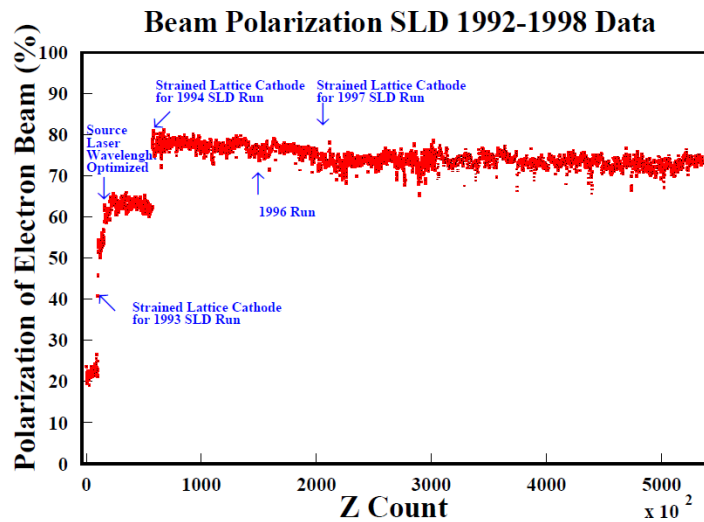
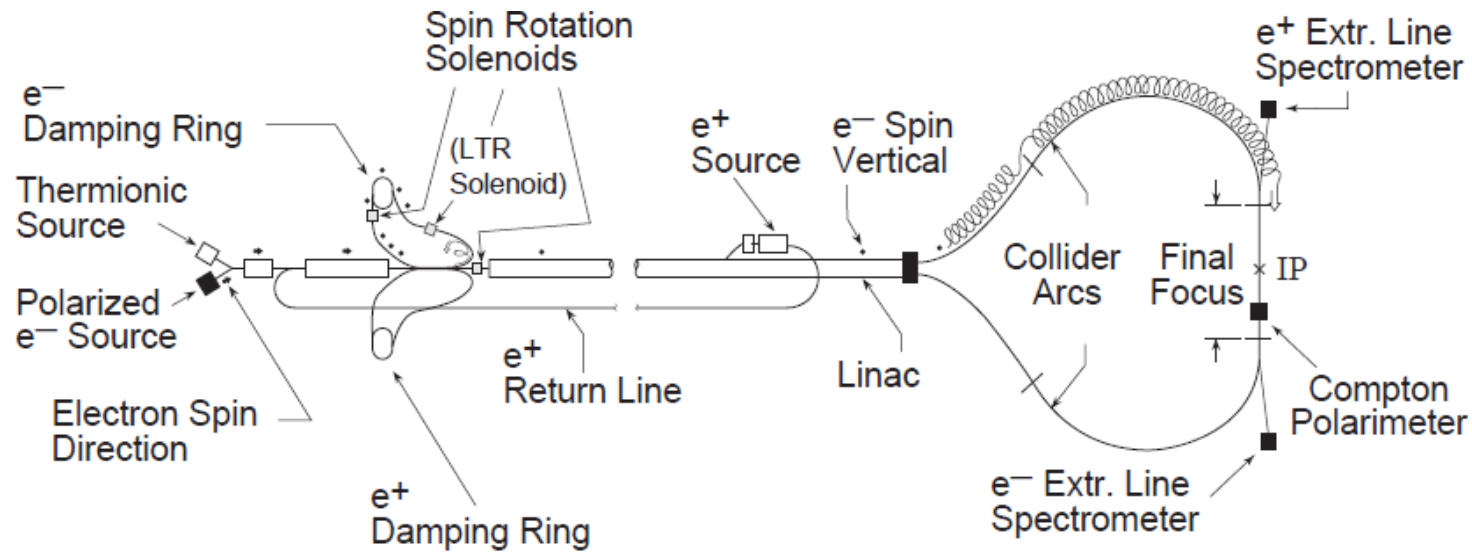



Polarizzazione dei fasci



- La sezione d'urto dipende dalla polarizzazione dei fasci collidenti

$$\frac{d\sigma_{ff}}{d\cos\theta} = \frac{3}{8}\sigma_{ff}^{\text{tot}} \left[(1 - \mathcal{P}_e \mathcal{A}_e)(1 + \cos^2\theta) + 2(\mathcal{A}_e - \mathcal{P}_e)\mathcal{A}_f \cos\theta \right]$$

$$A_{\text{FB}} = \frac{\sigma_{\text{F}} - \sigma_{\text{B}}}{\sigma_{\text{F}} + \sigma_{\text{B}}}$$

$$A_{\text{LR}} = \frac{\sigma_{\text{L}} - \sigma_{\text{R}}}{\sigma_{\text{L}} + \sigma_{\text{R}}} \frac{1}{\langle |\mathcal{P}_e| \rangle}$$

$$A_{\text{LRFB}} = \frac{(\sigma_{\text{F}} - \sigma_{\text{B}})_{\text{L}} - (\sigma_{\text{F}} - \sigma_{\text{B}})_{\text{R}}}{(\sigma_{\text{F}} + \sigma_{\text{B}})_{\text{L}} + (\sigma_{\text{F}} + \sigma_{\text{B}})_{\text{R}}} \frac{1}{\langle |\mathcal{P}_e| \rangle}$$

$$\mathcal{A}_f = \frac{g_{\text{Lf}}^2 - g_{\text{Rf}}^2}{g_{\text{Lf}}^2 + g_{\text{Rf}}^2} = \frac{2g_{\text{Vf}}g_{\text{Af}}}{g_{\text{Vf}}^2 + g_{\text{Af}}^2} = 2 \frac{g_{\text{Vf}}/g_{\text{Af}}}{1 + (g_{\text{Vf}}/g_{\text{Af}})^2}$$

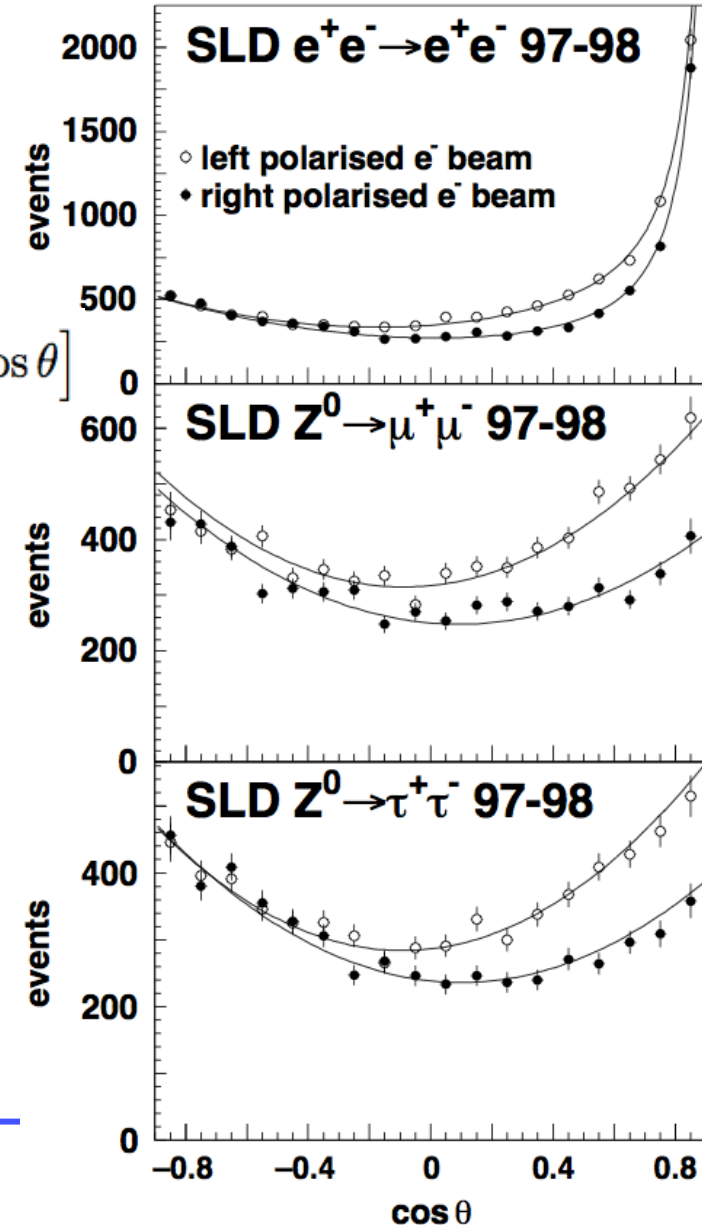



Polarizzazione stati finali (τ)



$$\mathcal{P}_\tau \equiv (\sigma_+ - \sigma_-)/(\sigma_+ + \sigma_-)$$

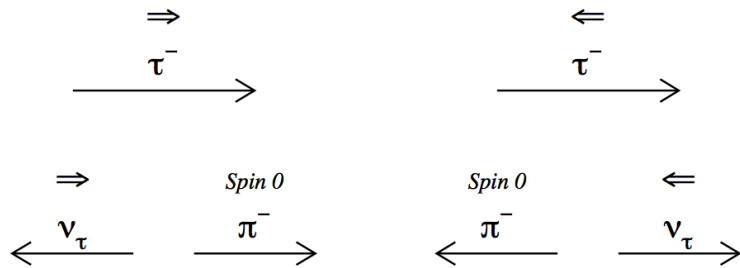

$$\frac{1}{\Gamma} \frac{d\Gamma}{d \cos \theta_\pi} = \frac{1}{2} (1 + \mathcal{P}_\tau \cos \theta_\pi)$$

θ_π nel sist. di riferimento a rip. del τ

Nel sistema del laboratorio:

$$\frac{1}{\Gamma} \frac{d\Gamma}{dx_\pi} = 1 + \mathcal{P}_\tau (2x_\pi - 1)$$

$$x_\pi = E_\pi / E_\tau$$

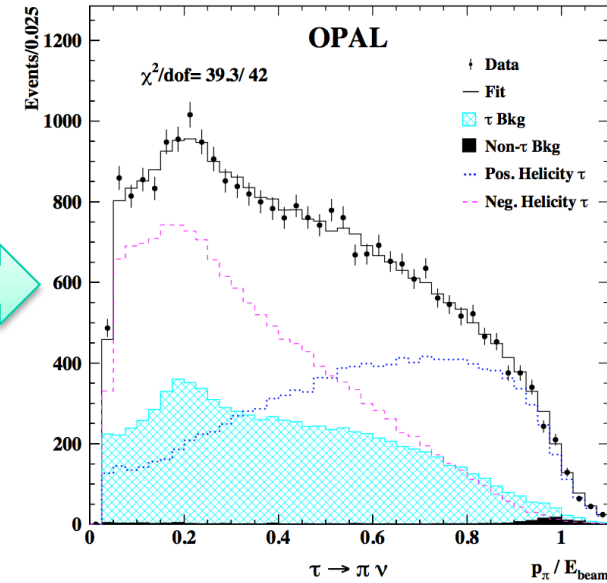
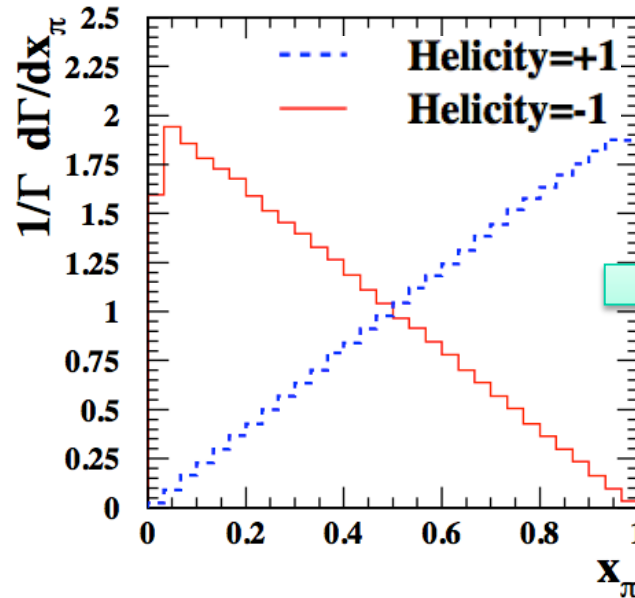



Polarizzazione per $\tau \rightarrow l\nu$



$$\frac{1}{\Gamma} \frac{d\Gamma}{dx_\ell} = \frac{1}{3} \left[(5 - 9x_\ell^2 + 4x_\ell^3) + \mathcal{P}_\tau (1 - 9x_\ell^2 + 8x_\ell^3) \right]$$

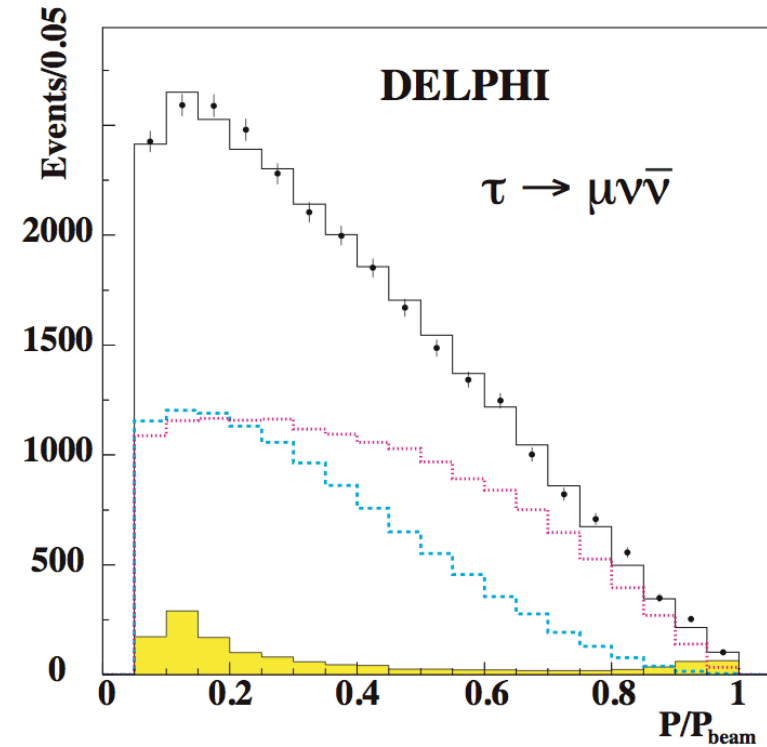
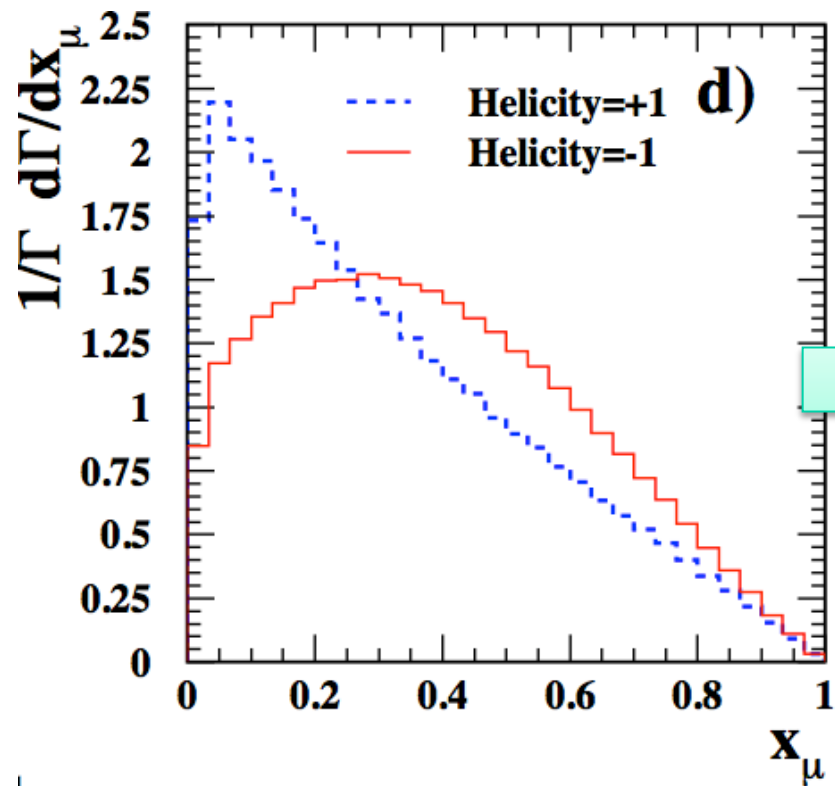

Per decadimenti $\tau \rightarrow \rho\nu$ e $a_1\nu$ è necessaria un'analisi di spin più complessa



Mettendo tutto insieme ...

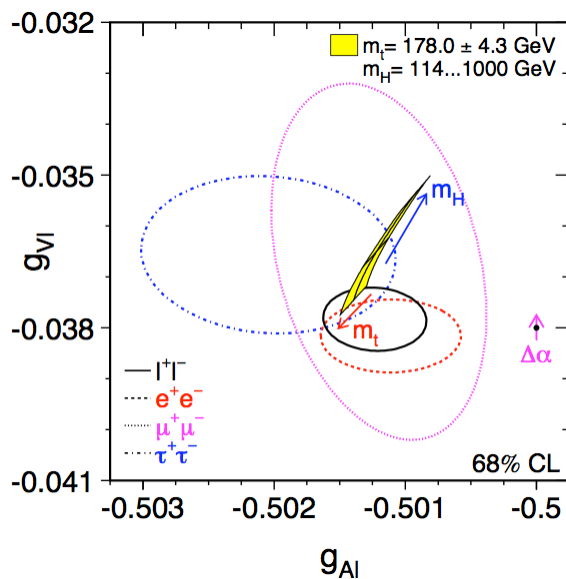
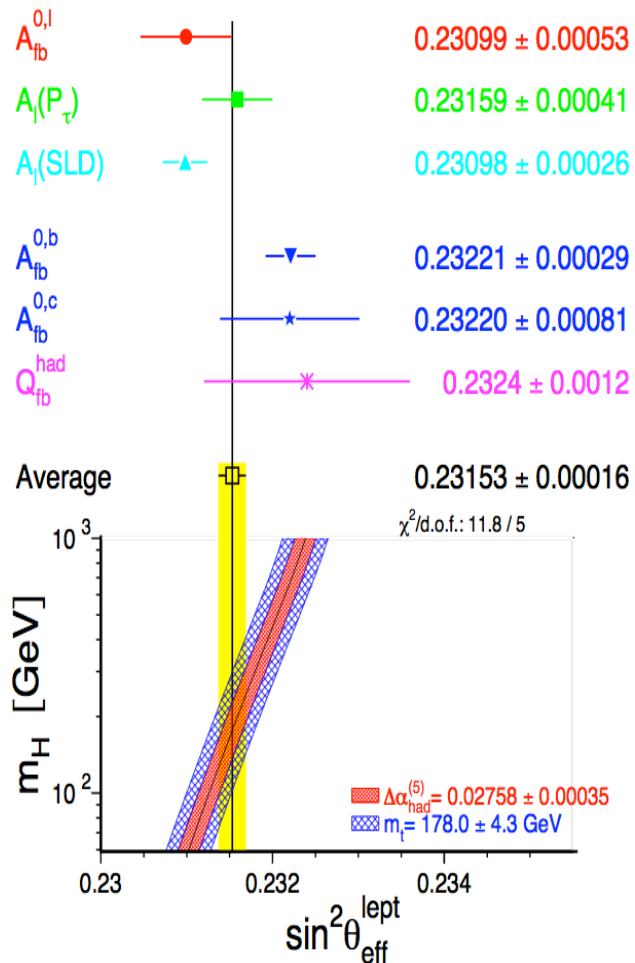

Top-Quark Mass [GeV]

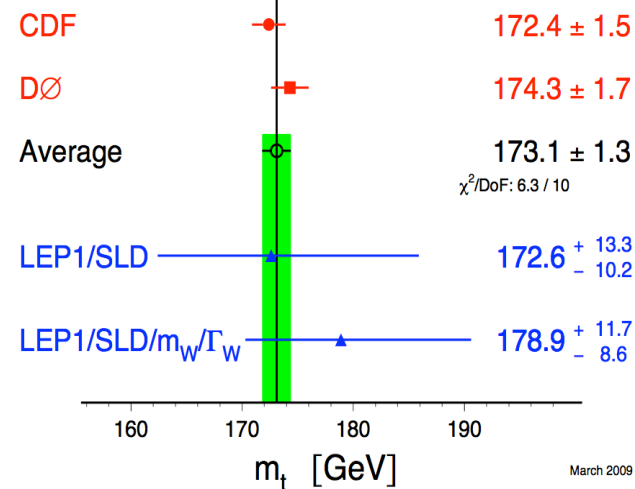

W-Boson Mass [GeV]

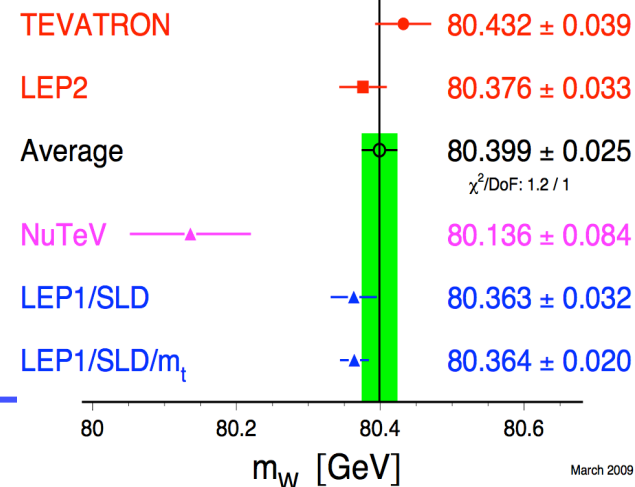

<http://lepewwg.web.cern.ch/LEPEWWG/>



Previsioni sul bosone di Higgs

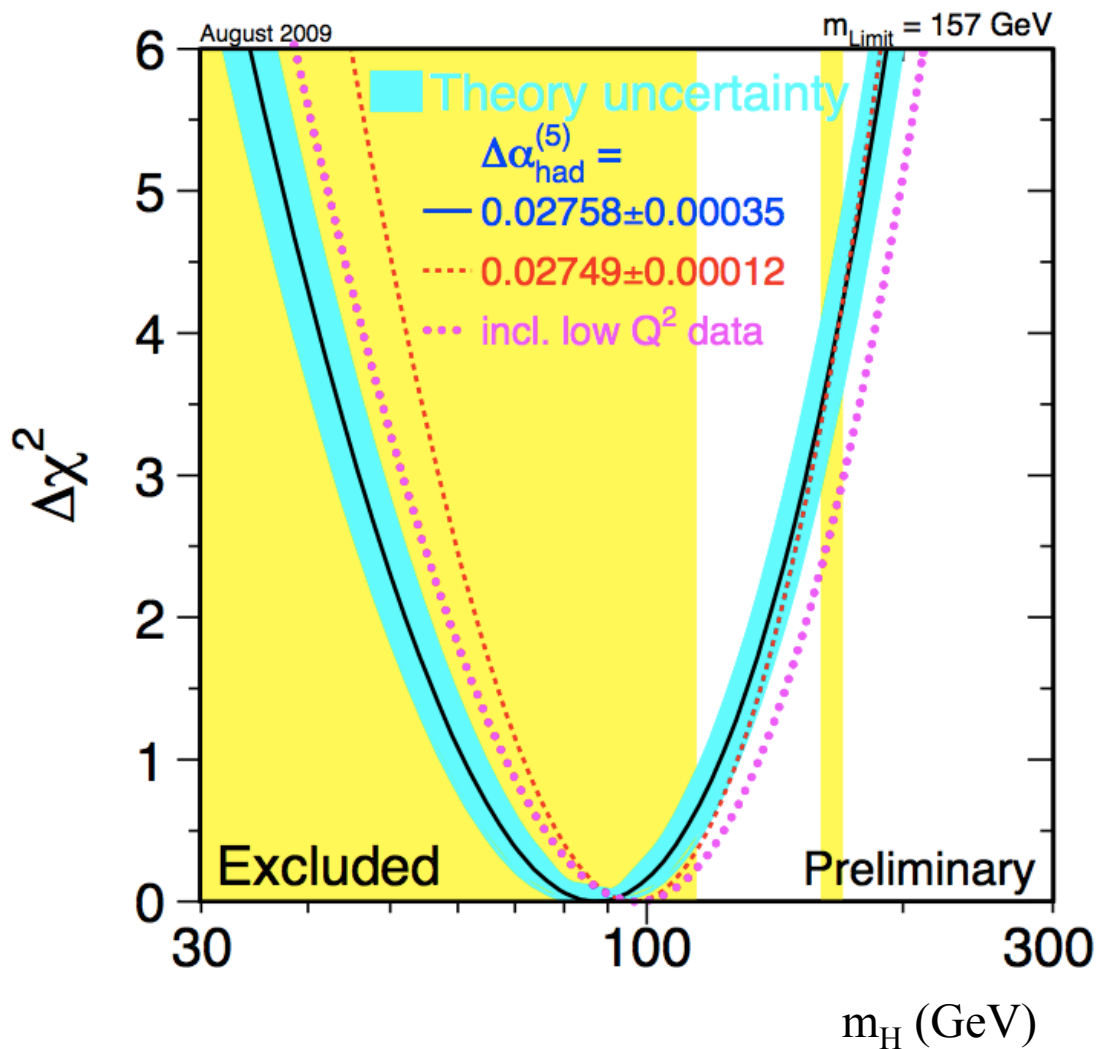



Accoppiamenti dell'Higgs



Feynman Rules

*They are independent
of the details of the
Higgs potential except the
vev*

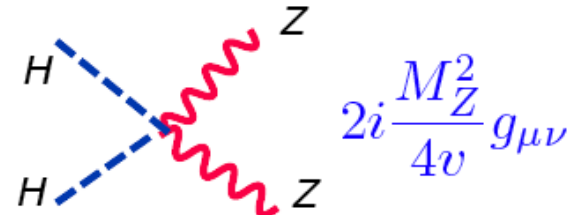
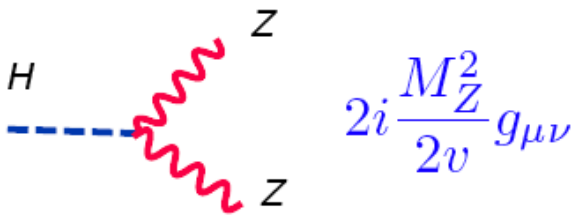
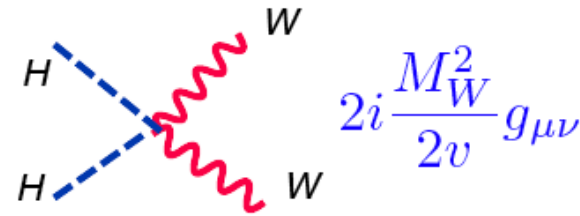
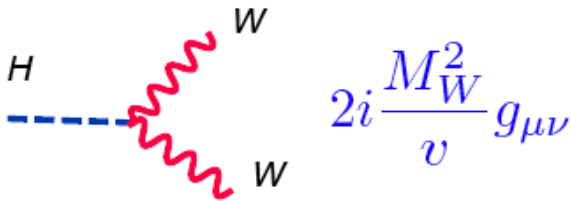
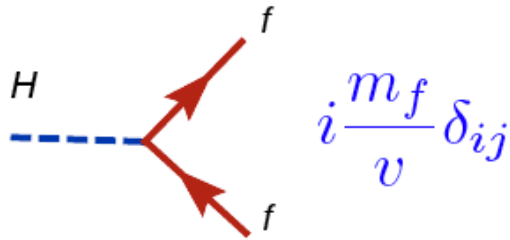



Decadimenti dell'Higgs

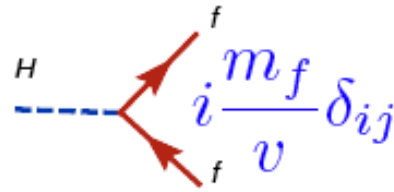

$$\Gamma(H \rightarrow f\bar{f}) = \frac{M_H}{8\pi} \left(\frac{M_f}{v}\right)^2 N_c \left(1 - \frac{4M_f^2}{M_H^2}\right)^{3/2}$$

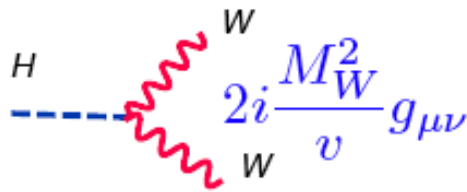

$$\Gamma(H \rightarrow WW) = \frac{M_H}{16\pi} \left(\frac{M_H}{v}\right)^2 \left(1 - \frac{4M_W^2}{M_H^2}\right)^{1/2} \times \left[1 - 4\left(\frac{M_W^2}{M_H^2}\right) + 12\left(\frac{M_W^2}{M_H^2}\right)^2\right]$$

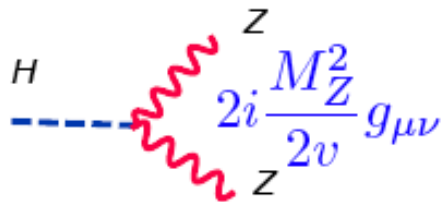

$$\Gamma(H \rightarrow ZZ) = \frac{M_H}{32\pi} \left(\frac{M_H}{v}\right)^2 \left(1 - \frac{4M_Z^2}{M_H^2}\right)^{1/2} \times \left[1 - 4\left(\frac{M_Z^2}{M_H^2}\right) + 12\left(\frac{M_Z^2}{M_H^2}\right)^2\right]$$



Produzione di Higgs a LEP

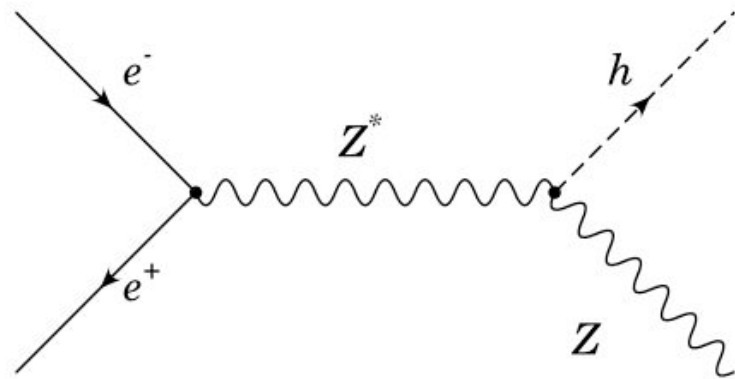

L'Higgs decade prevalentemente in bb alle energie di LEP

I possibili decadimenti della Z producono signature sperimentali diverse

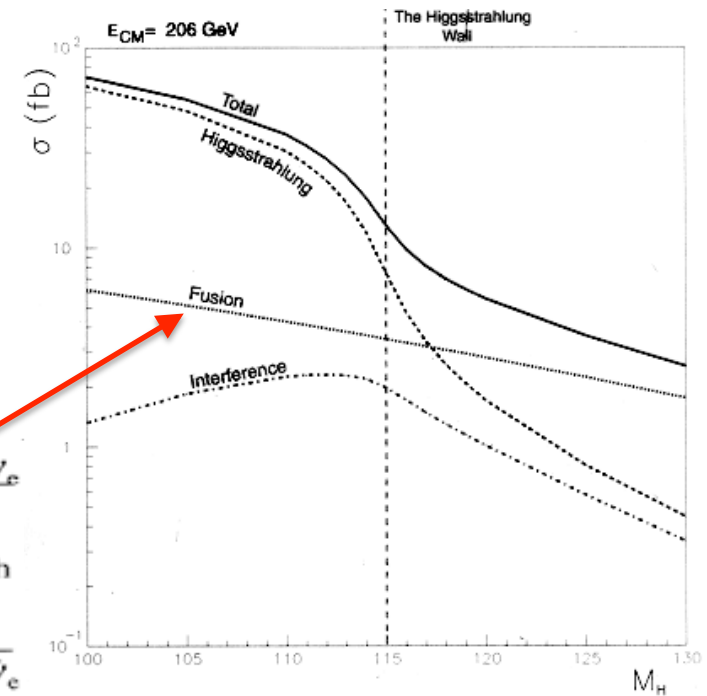
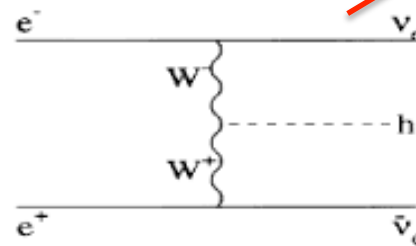
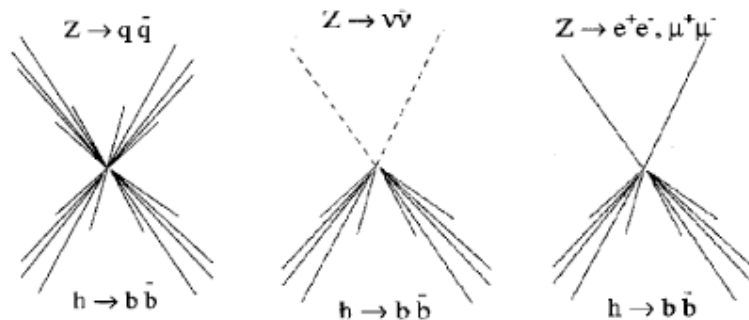



Candidato Higgs (Aleph)



Zoom right inside
the beam pipe:

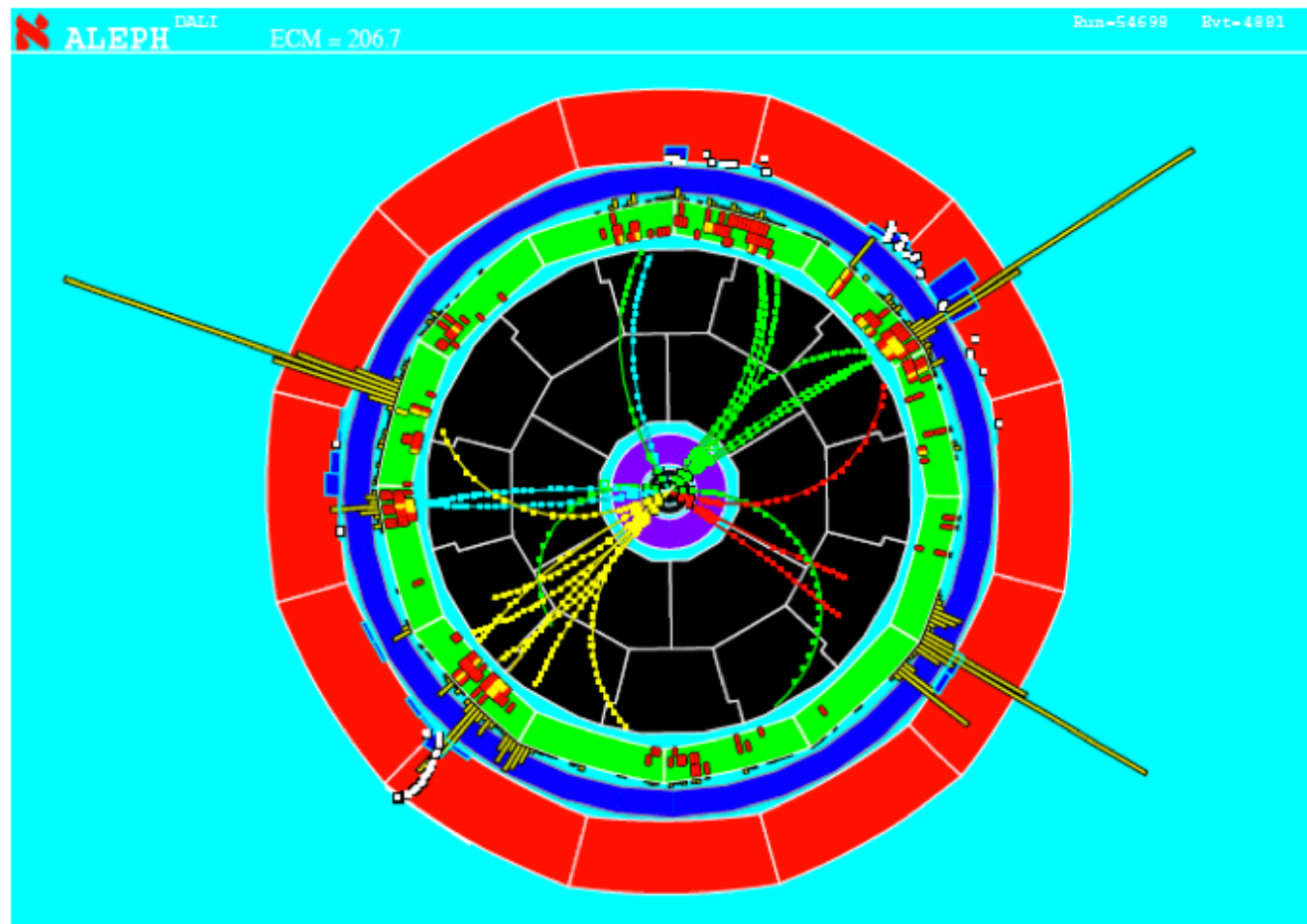
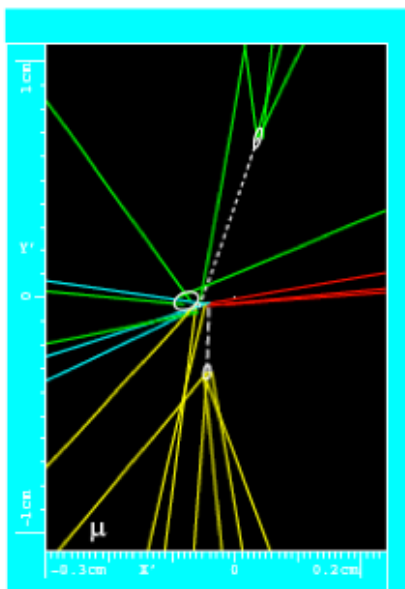



Produzione di Higgs vs \sqrt{s}

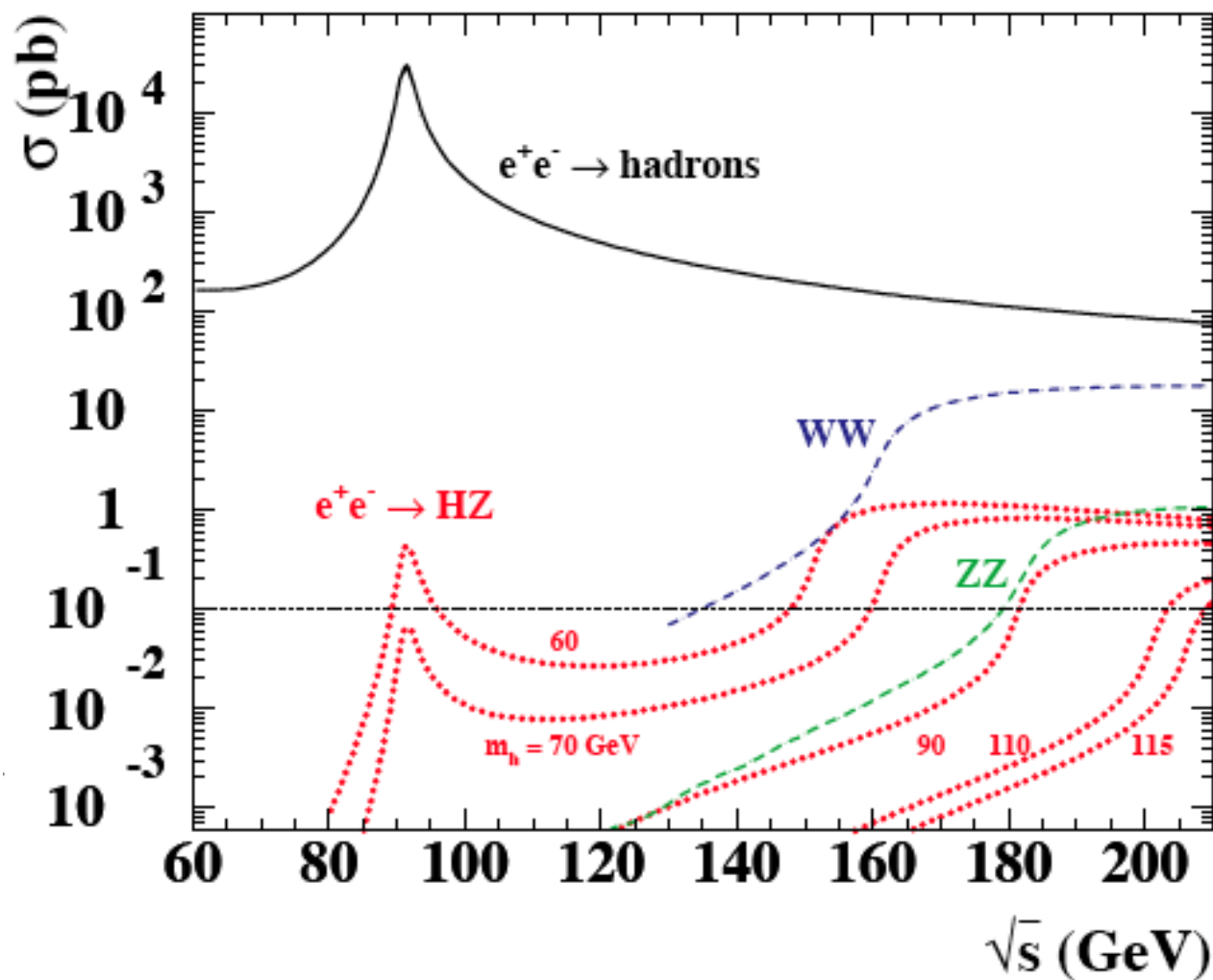



Combined Higgs search at LEP-II



- Extended likelihood definition:

$$L(\eta) = \prod_{k=1}^{n_{\text{ch}}} \frac{e^{-(\eta s_k(m_H) + b_k)} (\eta s_k(m_H) + b_k)^{n_k}}{n_k!} \times \prod_{j=1}^{n_k} \frac{\eta s_k(m_H) S_k(x_{jk}^{\vec{}}; m_H) + b_k B_k(x_{jk}^{\vec{}})}{\eta s_k(m_H) + b_k}$$

- $\eta = 0$ for b only, 1 for $s + b$ hypotheses
- Likelihood ratio:

$$-2 \ln Q(m_H) = 2 \sum_{k=1}^{n_{\text{ch}}} \left[s_k(m_H) - \sum_{j=1}^{n_k} \ln \left(1 + \frac{s_k(m_H) S_k(x_{jk}^{\vec{}}; m_k)}{b_k B_k(x_{jk}^{\vec{}})} \right) \right]$$



Higgs candidates mass

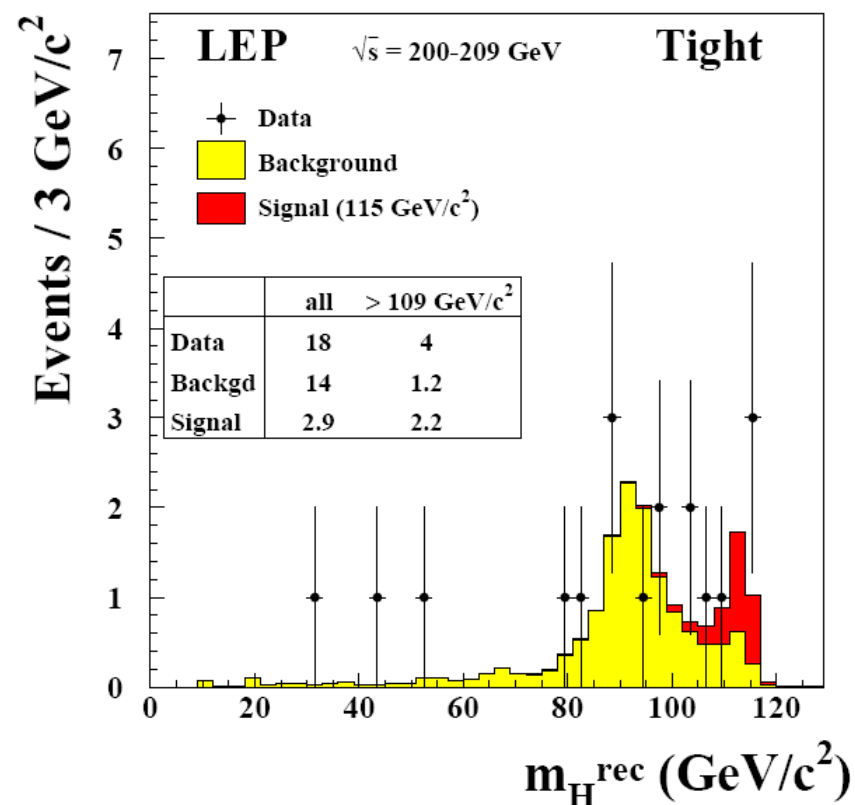
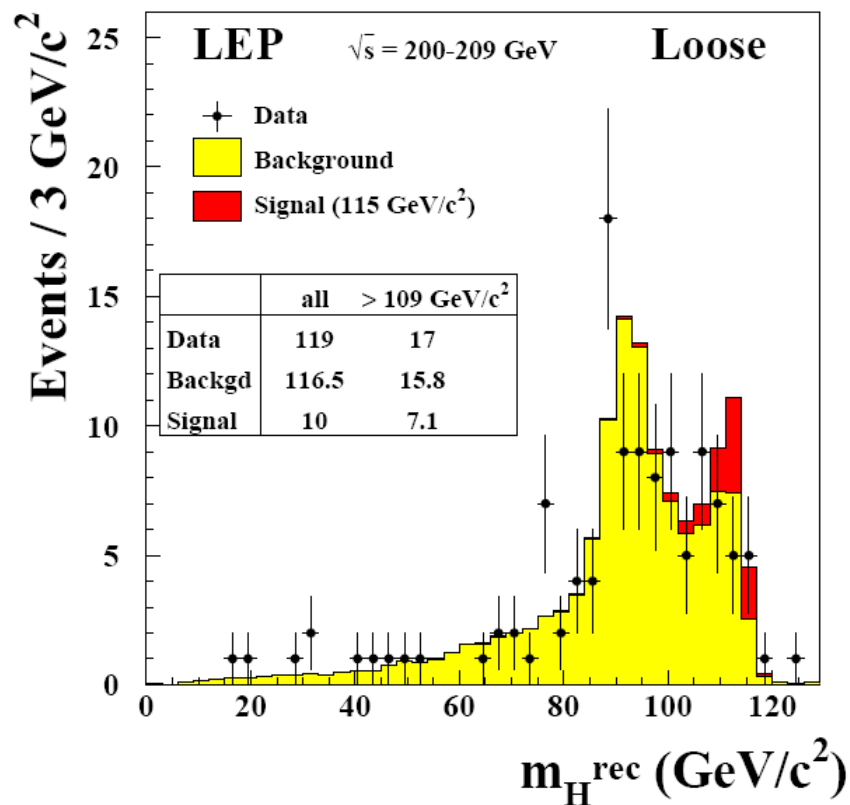



Mass scan plot

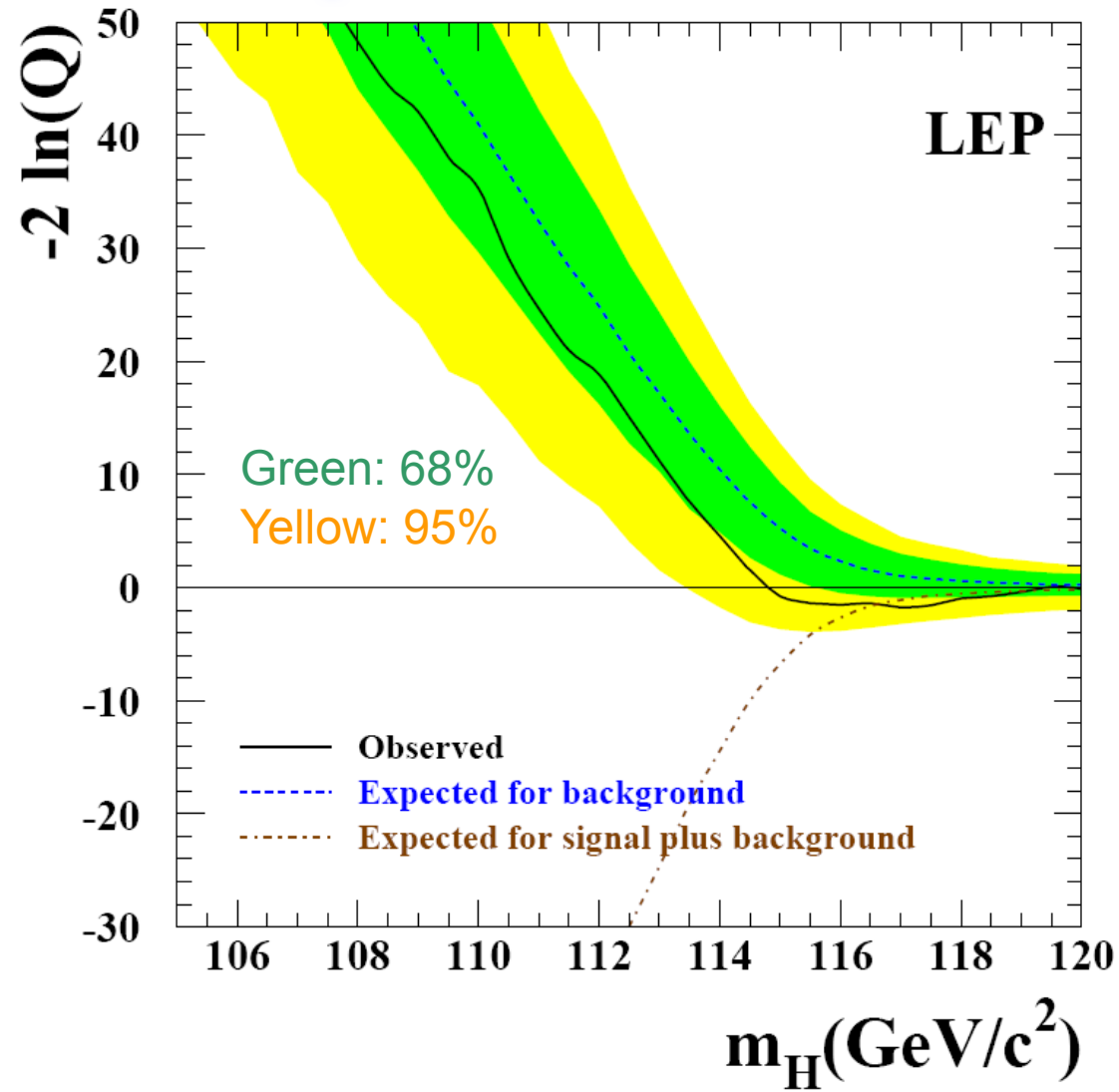



Mass scan by experiment

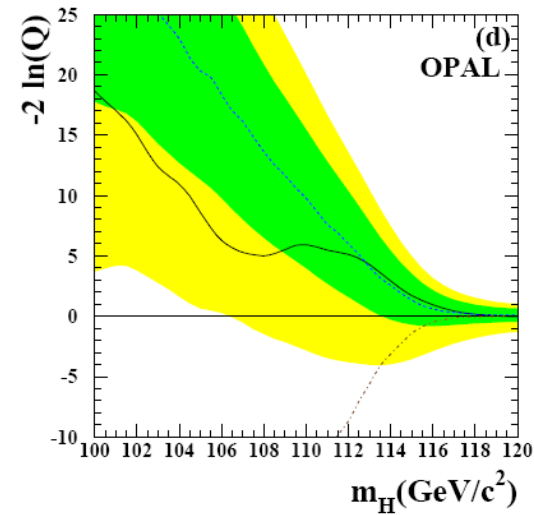
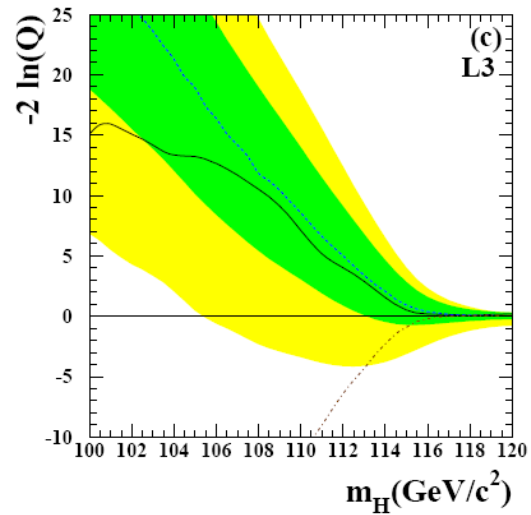
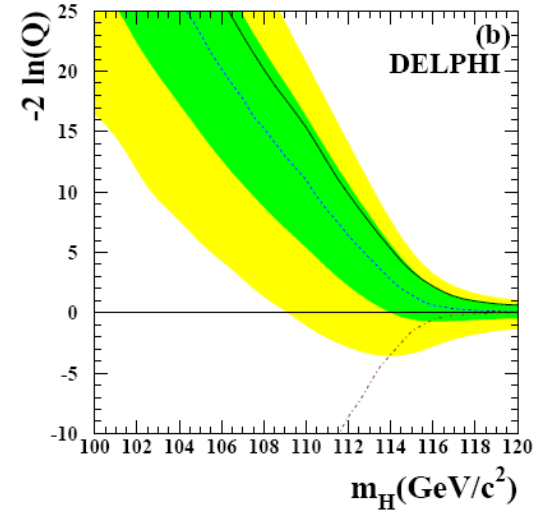
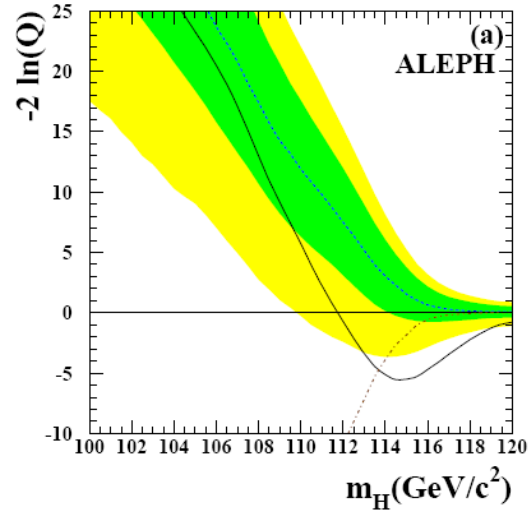



Mass scan by channel

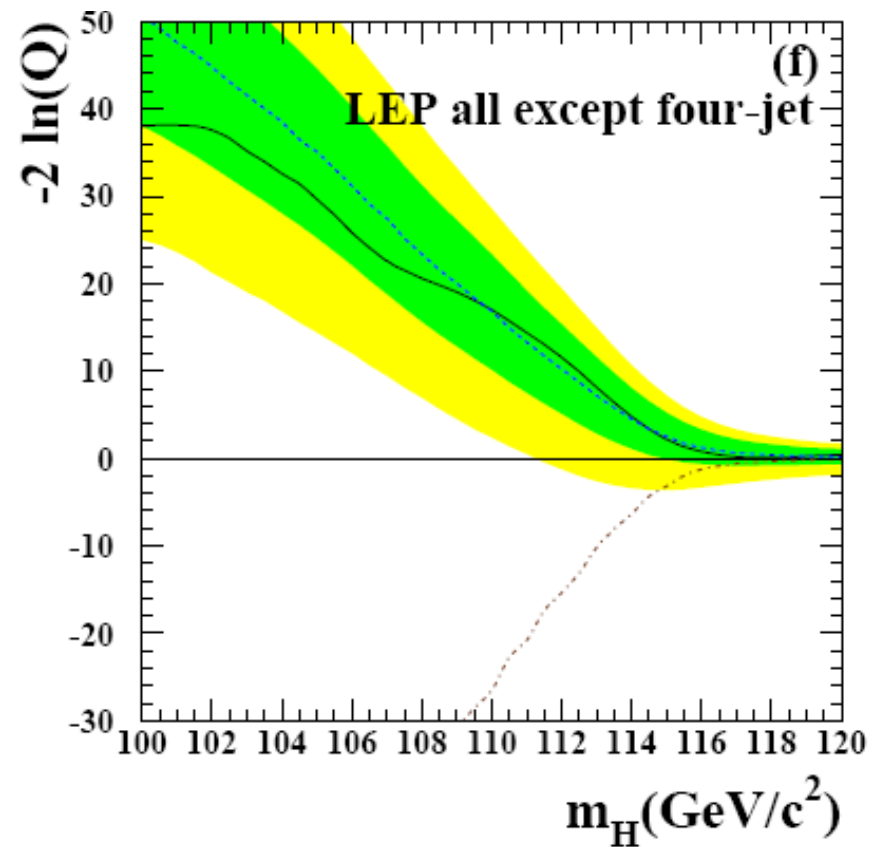
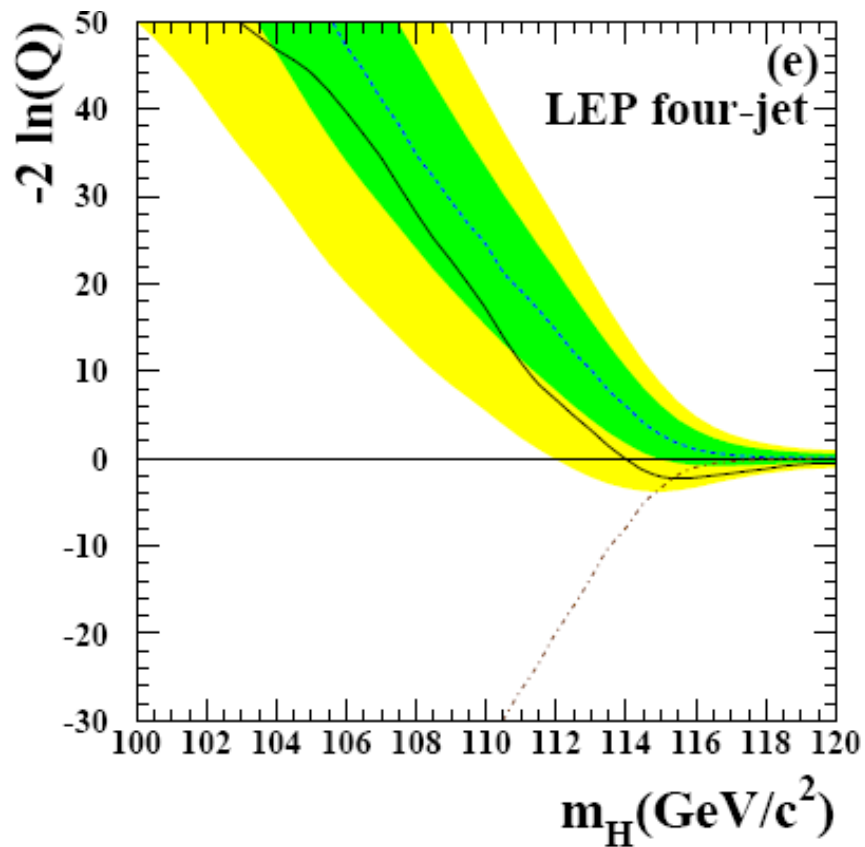



Signal hypothesis C.L.

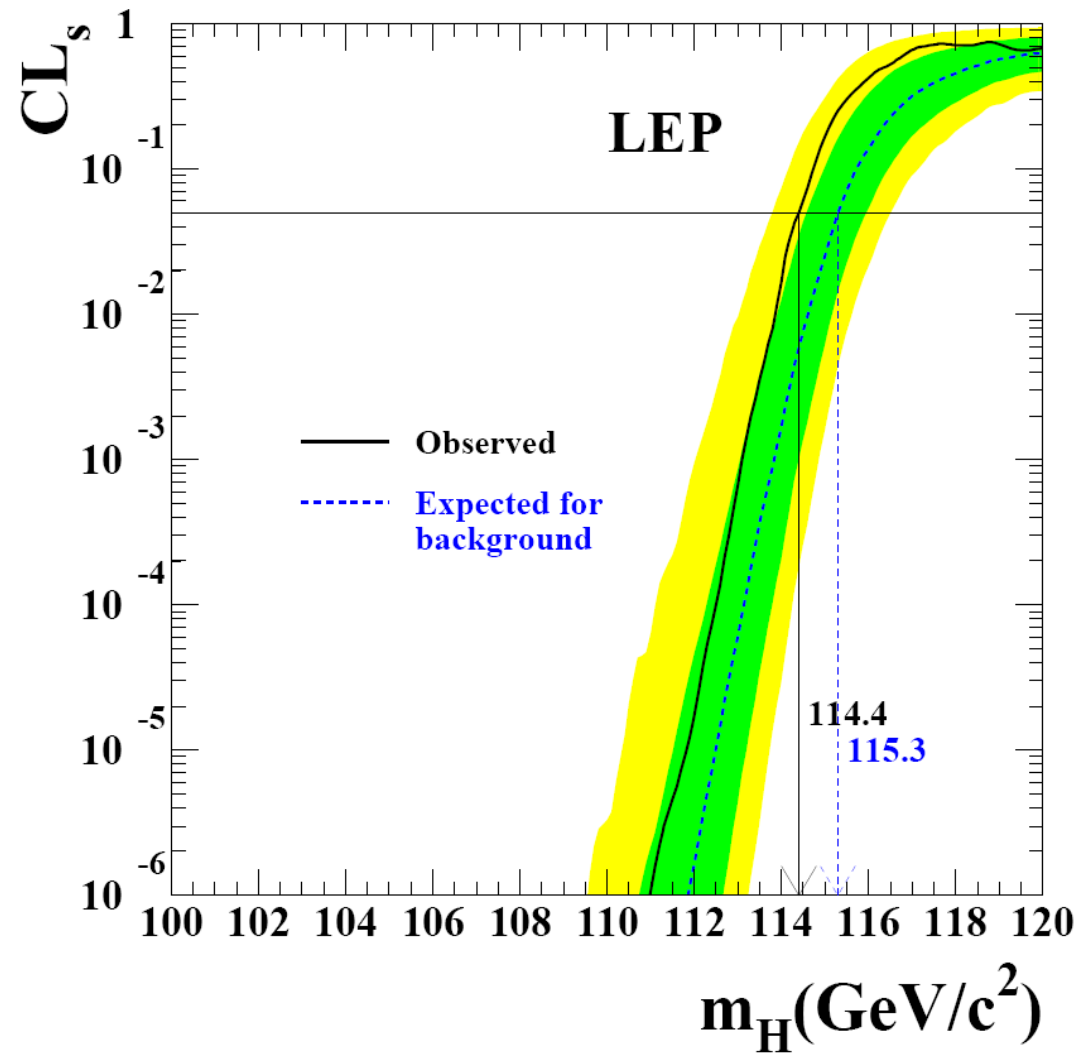



Higgs al Tevatron ($\sqrt{s} = 1.96 \text{ TeV}$)

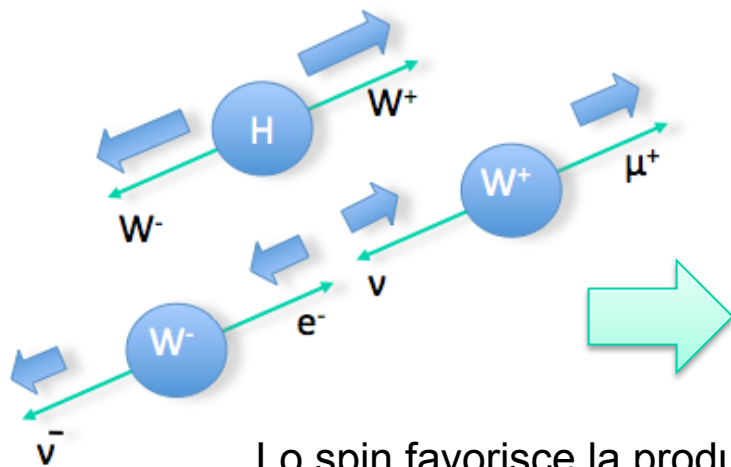
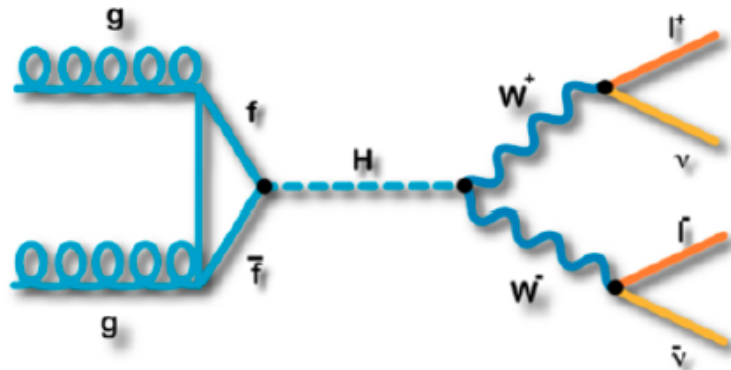

Lo spin favorisce la produzione di leptoni nella stessa direzione

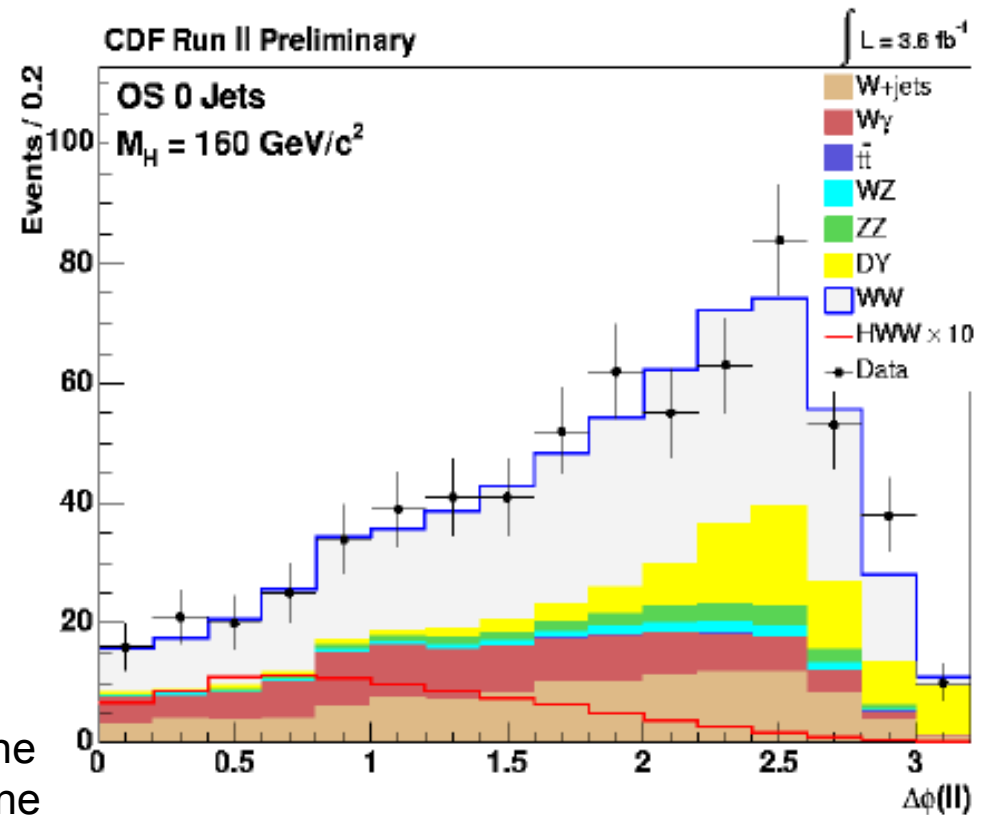



Higgs limit from Tevatron



Tevatron Run II Preliminary, $L=2.0-5.4 \text{ fb}^{-1}$

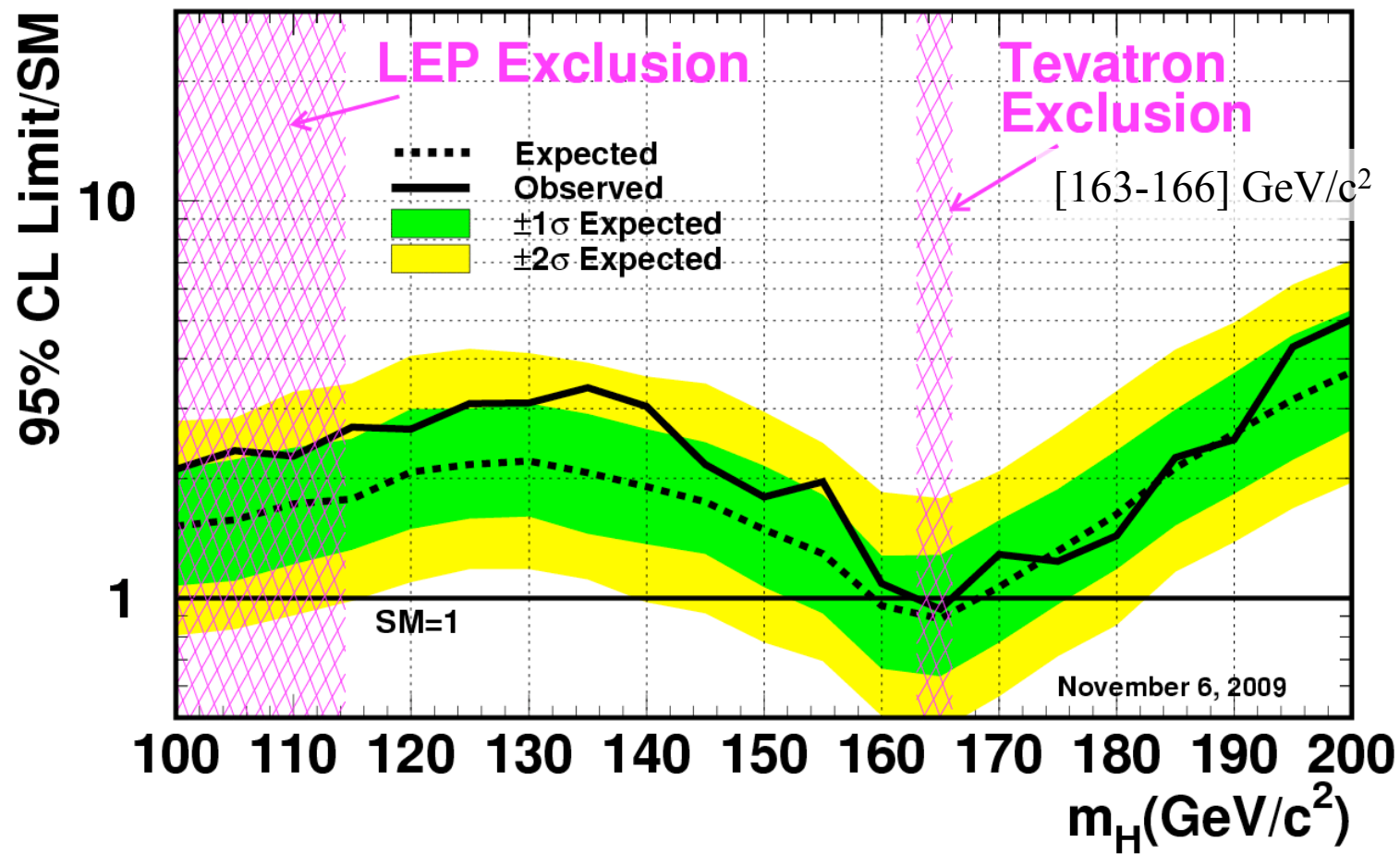



Decadimenti in funzione di m_H

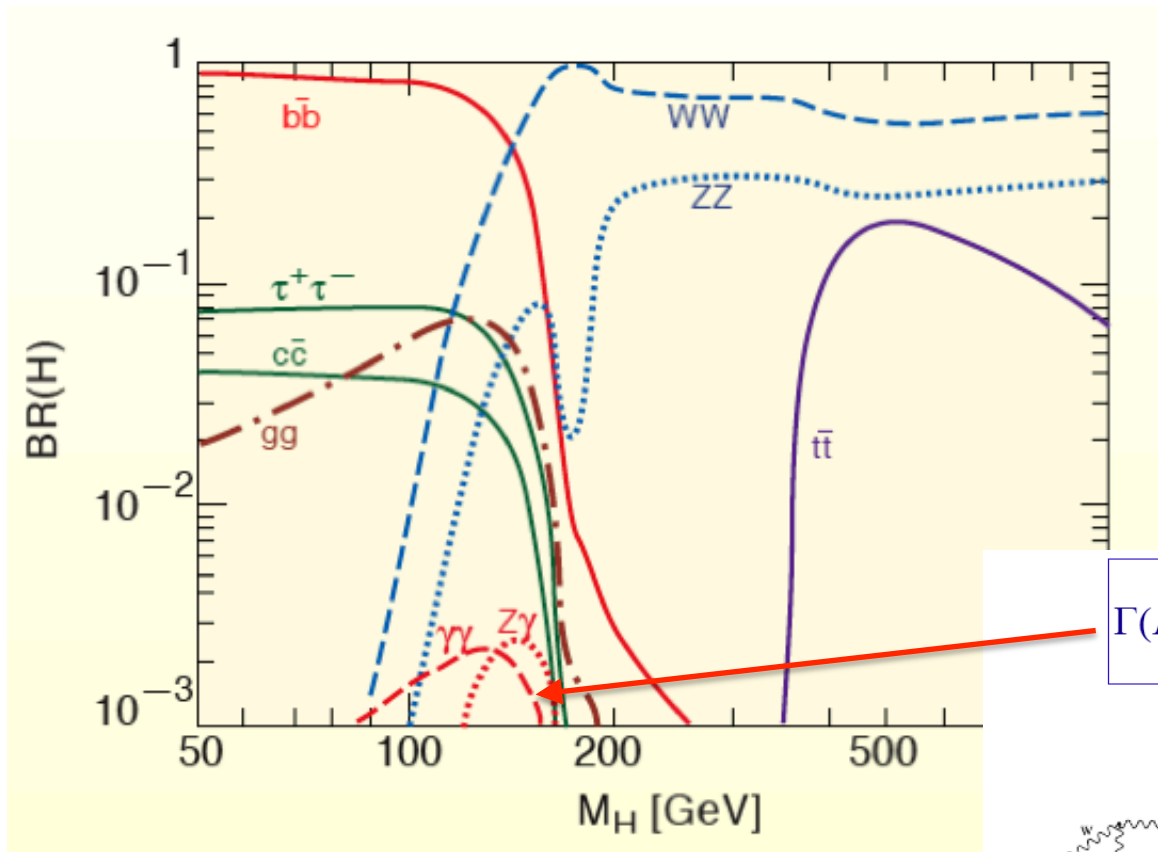

$$\Gamma(H \rightarrow \gamma\gamma) \approx \frac{\alpha^3}{256\pi^2 s_\theta^2} \frac{M_H^3}{M_W^2} \left| 7 - \frac{16}{9} + \dots \right|^2$$

W top

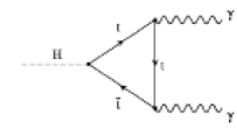
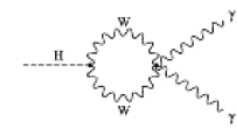
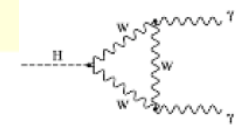



Produzione di Higgs a LHC

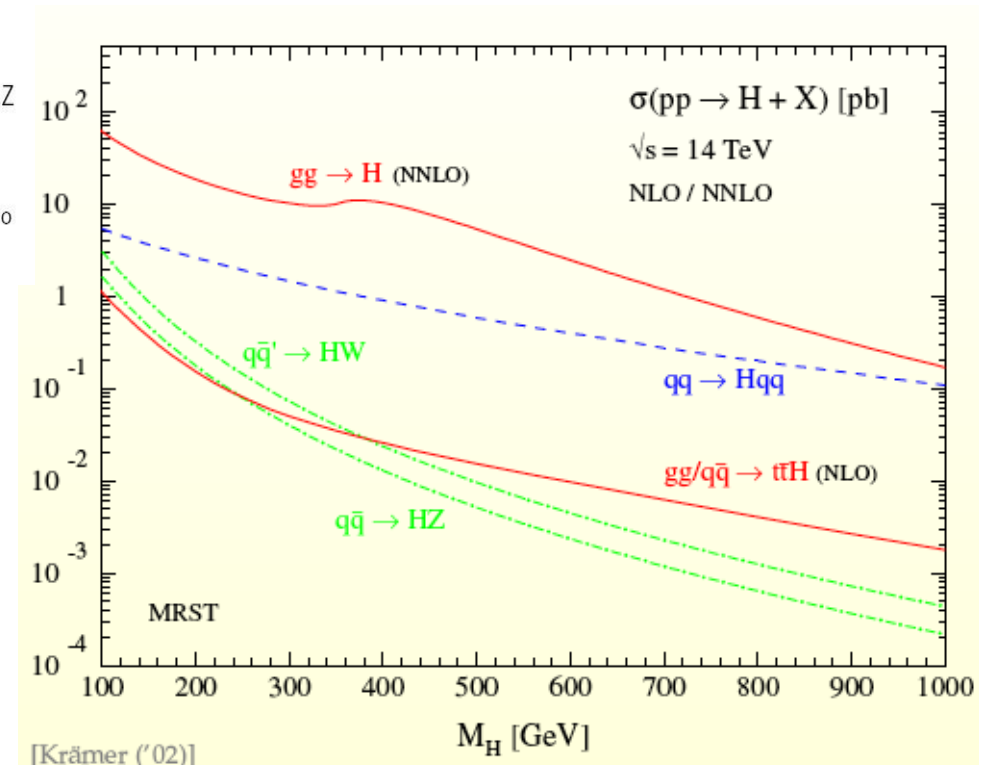
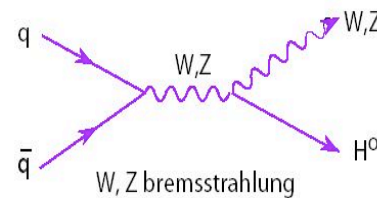
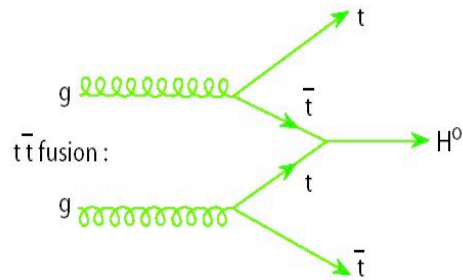
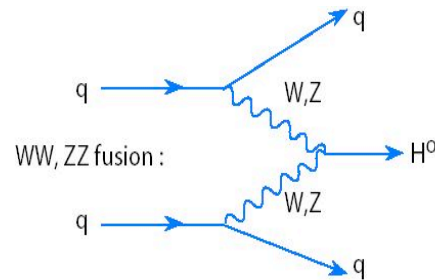
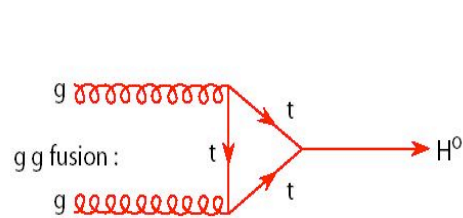



Ricerca dell'Higgs ad LHC



- Canale importante per $m_H < 140$ GeV
 - Regione favorita da LEP

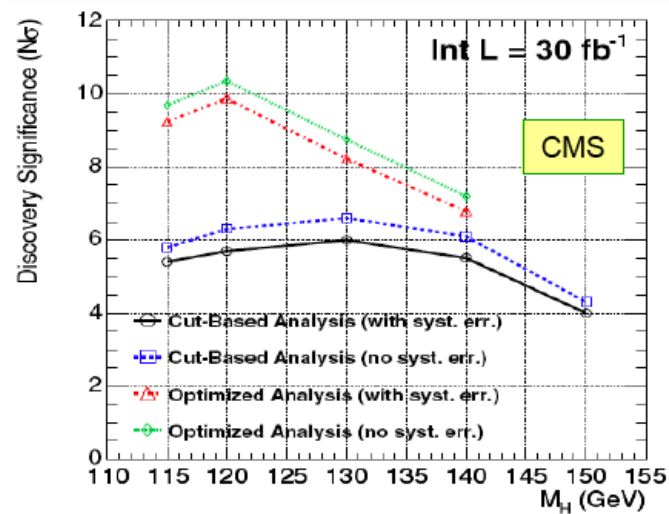
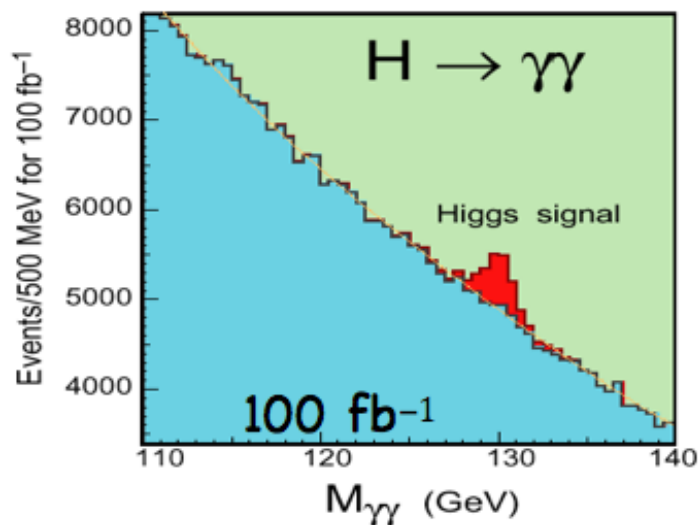
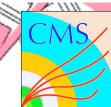
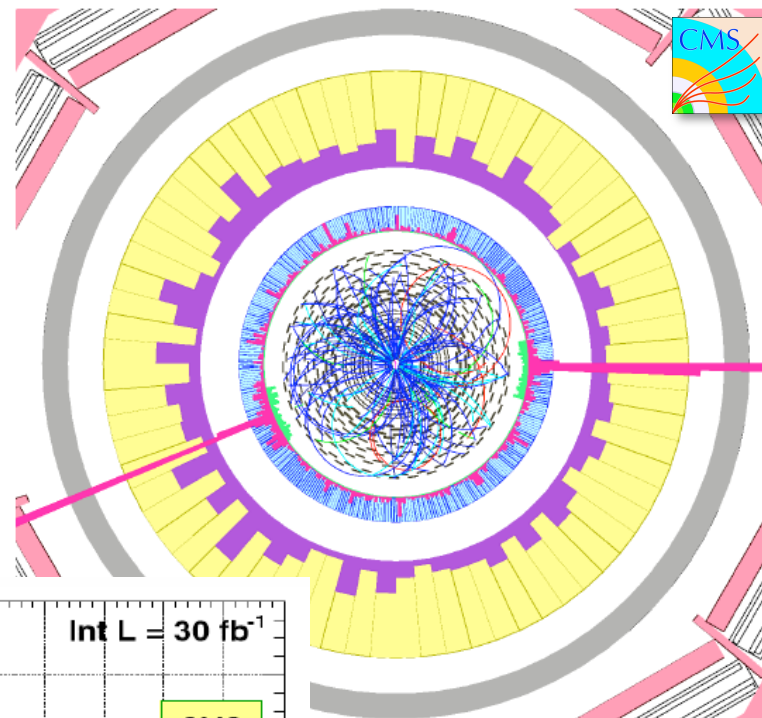



$H \rightarrow WW \rightarrow l\nu l\nu$



- Accessibile se $m_H > 2m_W$
- Regione preferita = area esclusa da Tevatron

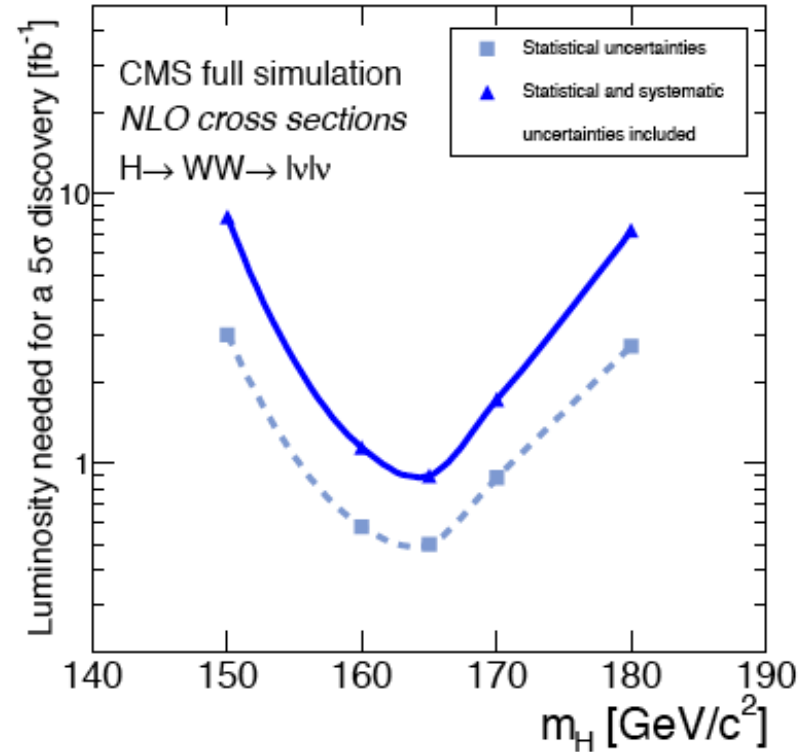
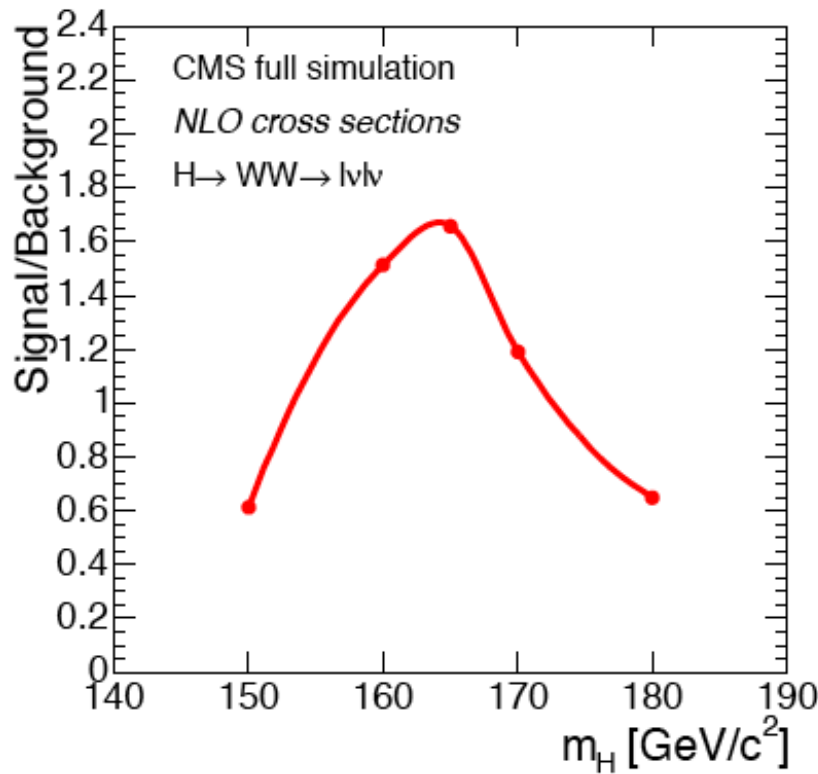



$H \rightarrow ZZ^{(*)} \rightarrow 4l$



- Accessibile se $m_H > 2m_Z$

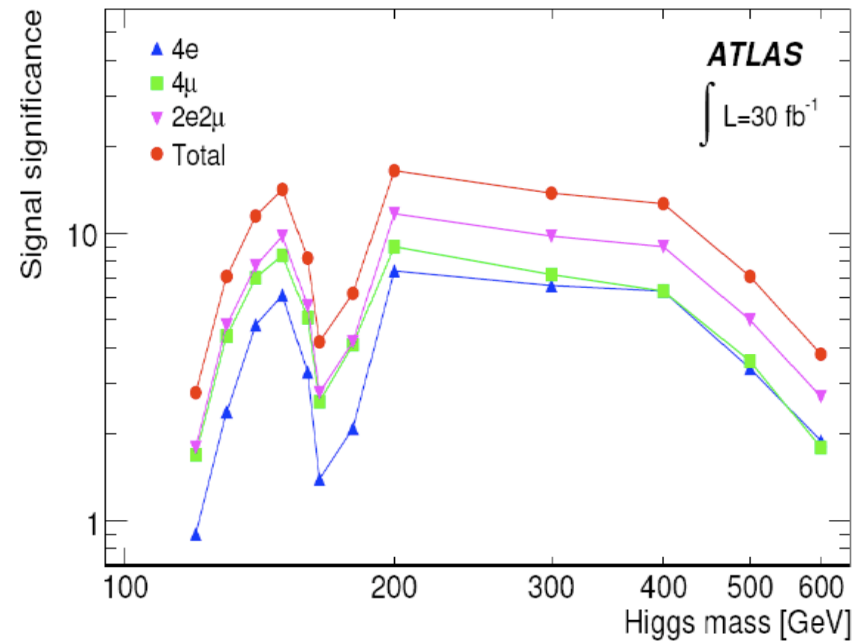
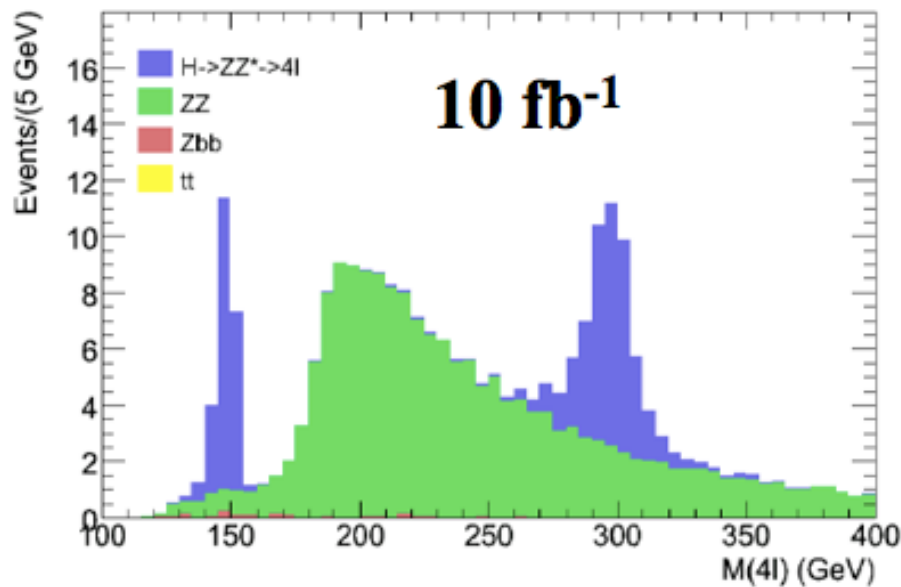



Analisi combinata



- Tutti i canali sono importanti perché contribuiscono in diverse regioni di massa

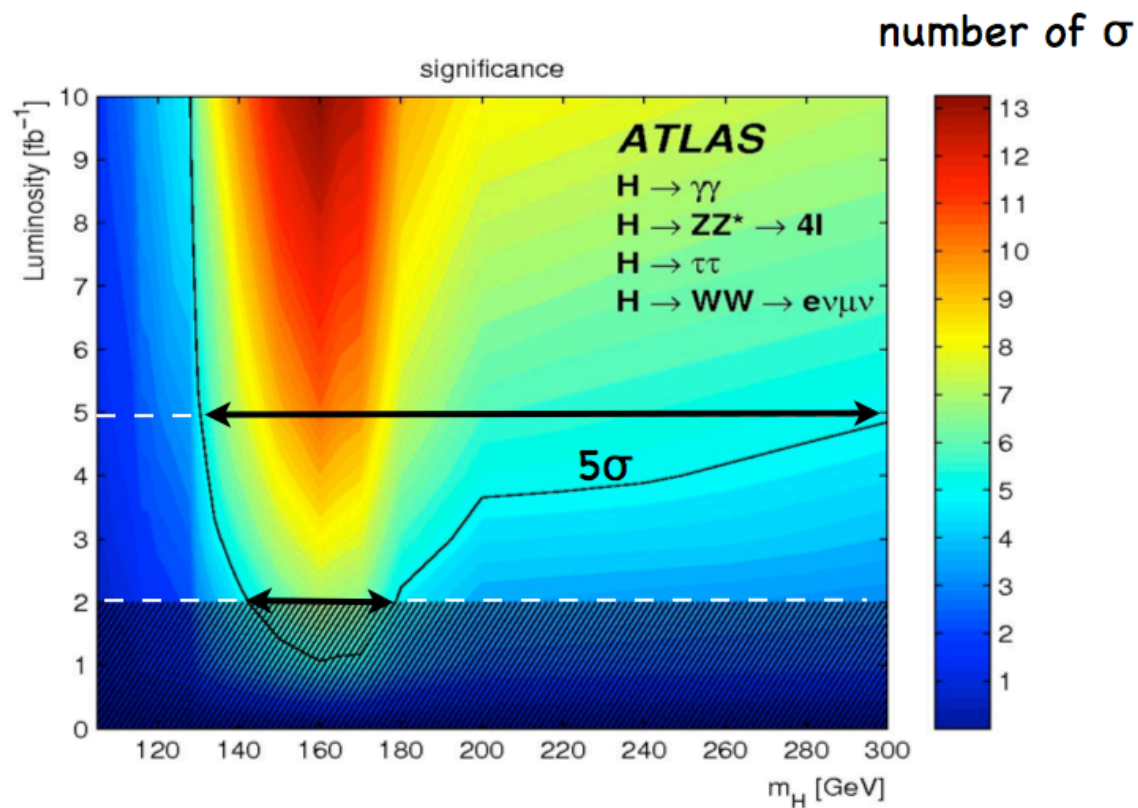



The Unitarity Triangle

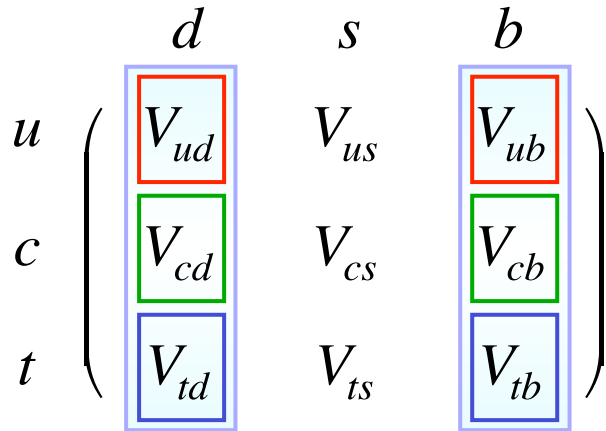

- Quark mixing is described by the CKM matrix
- Unitarity relations on matrix elements lead to a triangle in the complex plane

$$V_{ud}V_{ub}^* + V_{cd}V_{cb}^* + V_{td}V_{tb}^* = 0$$

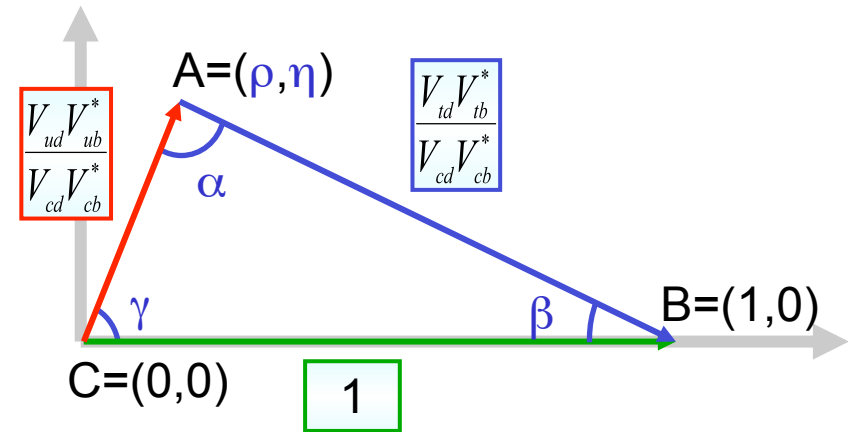



Inputs



Constraints, Parameters	Value	Gauss Error	Flat Error	Comments
λ	0.2258	0.0014	-	
$ V_{cb} (10^{-3})$	39.2	1.1	-	Average of exclusive
$ V_{cb} (10^{-3})$	41.7	0.7	-	Average of inclusive
$ V_{ub} 10^{-4} (\text{excl.})$	35.0	4.0	-	HFAG BR + Lattice QCD
$ V_{ub} 10^{-4} (\text{incl. HFAG})$	39.9	1.5	4.0	HFAG average
$m_b (\text{GeV}/c^2)$	4.21	0.08	-	
$m_c (\text{GeV}/c^2)$	1.3	0.1	-	
$\Delta(m_d) (\text{ps}^{-1})$	0.507	0.005	-	WA (CDF/CLEO/LEP/Babar/Belle)
$\Delta(m_s) (\text{ps}^{-1})$	17.77	0.12	-	CDF Likelihood is used.
$m_t (\text{GeV}/c^2)$	161.2	1.7	-	(CDF/D0)
$f_{B_s} \sqrt{B_{B_s}} (\text{MeV})$	270	30	-	Lattice QCD
ξ	1.21	0.04	-	Lattice QCD
$ \epsilon_K 10^{-3}$	2.280	0.013	-	
B_K	0.75	0.07	-	Lattice QCD
$f_K (\text{GeV})$	0.160	-	-	
$\Delta(m_K) (10^{-2} \text{ps}^{-1})$	0.5301	-	-	
$\alpha_s(M_Z)$	0.119	0.003	-	
$G_F (10^{-5} \text{GeV}^{-2})$	1.16639	-	-	
$m_W (\text{GeV}/c^2)$	80.425	-	-	
$m_{B_d} (\text{GeV}/c^2)$	5.279	-	-	
$m_{B_s} (\text{GeV}/c^2)$	5.375	-	-	
$m_{K^0} (\text{GeV}/c^2)$	0.497648	-	-	



Unitarity Triangle fit

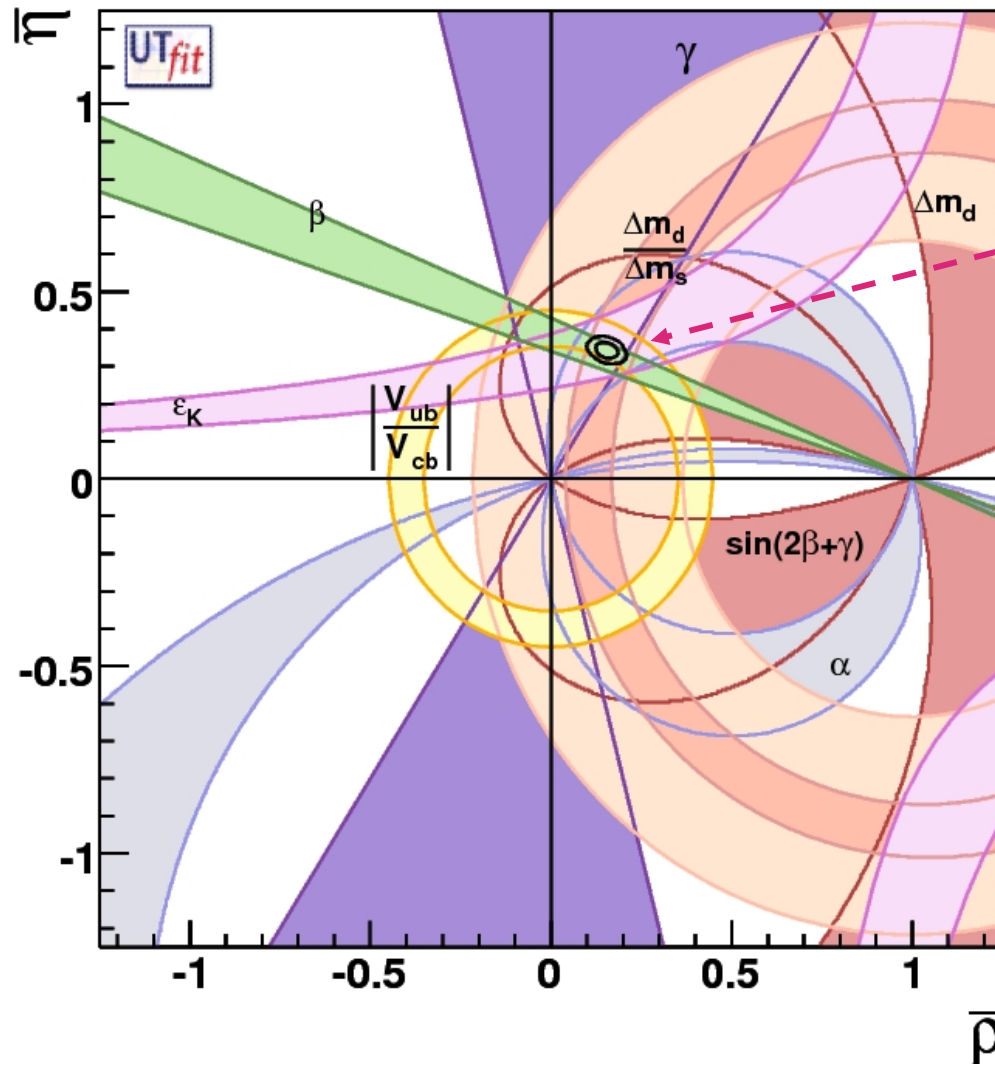

68%, 95% contours



PDFs for ρ and η

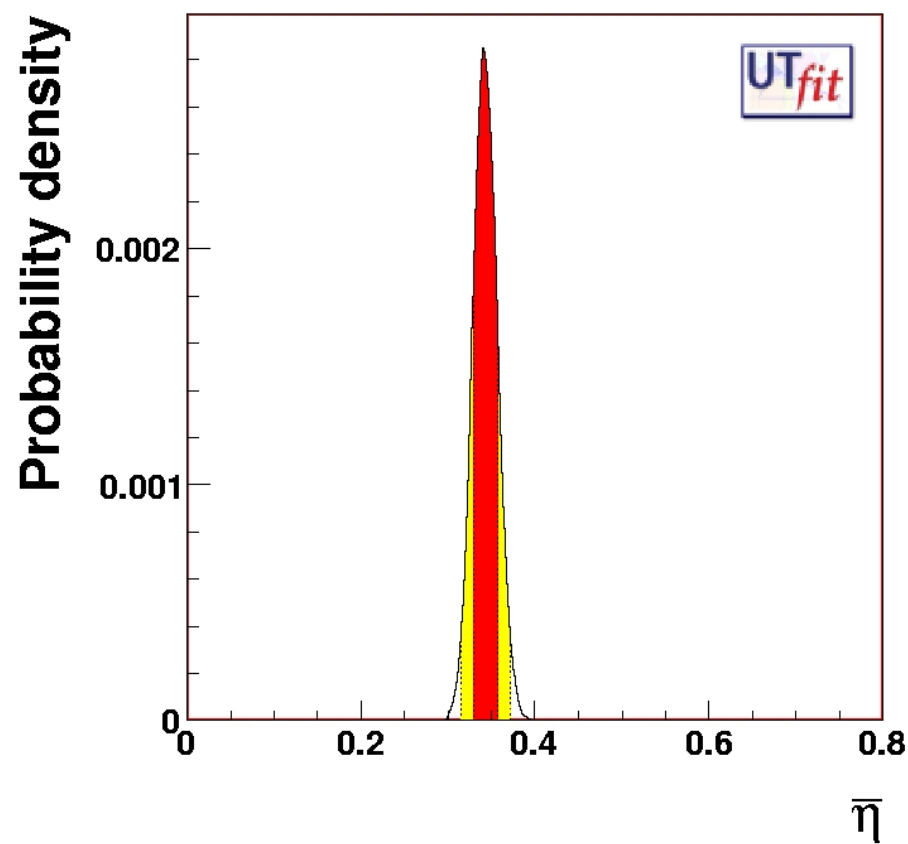
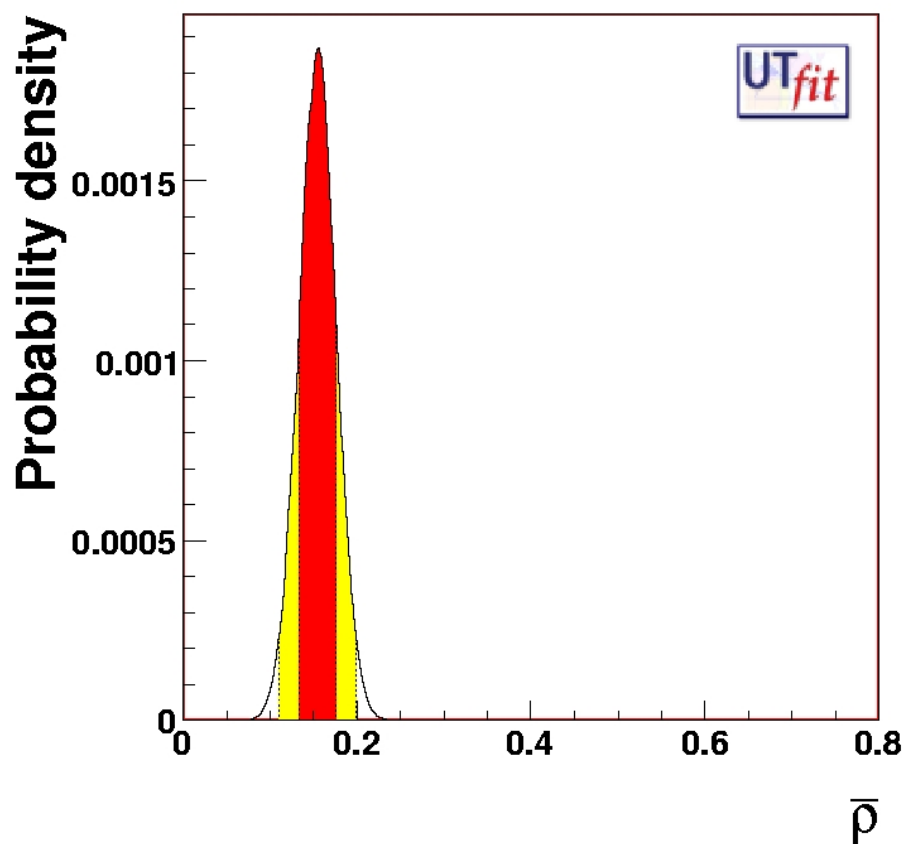



Unificazione delle interazioni

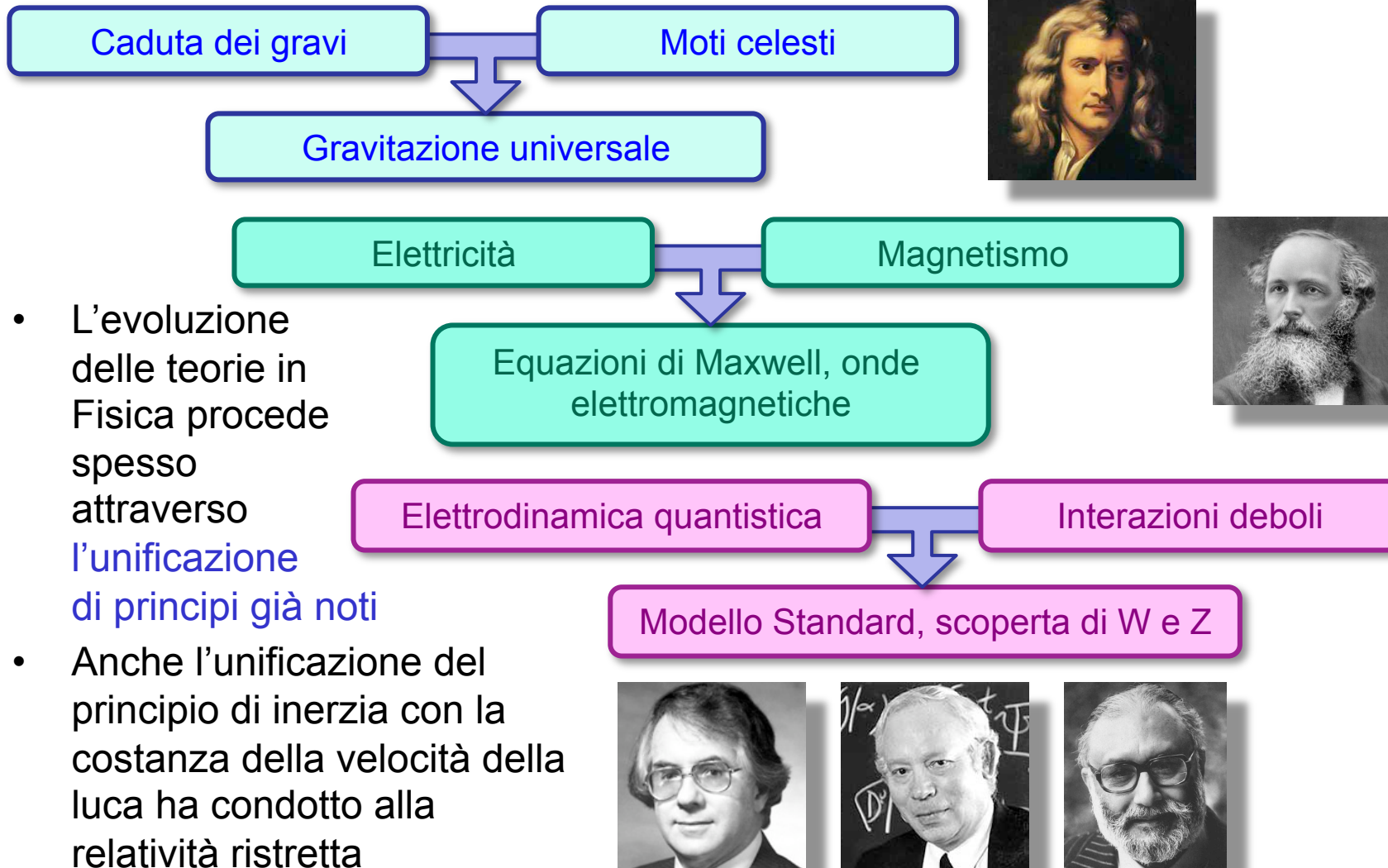



La Grande Unificazione



- Ognuna delle **quattro interazioni fondamentali** è mediata da una **particella** (bosone vettore)
- Il **Modello Standard** unifica le interazioni elettromagnetiche e nucleare debole
- È possibile che tutte le forze siano in realtà **unificate** in un'unica interazione fondamentale?

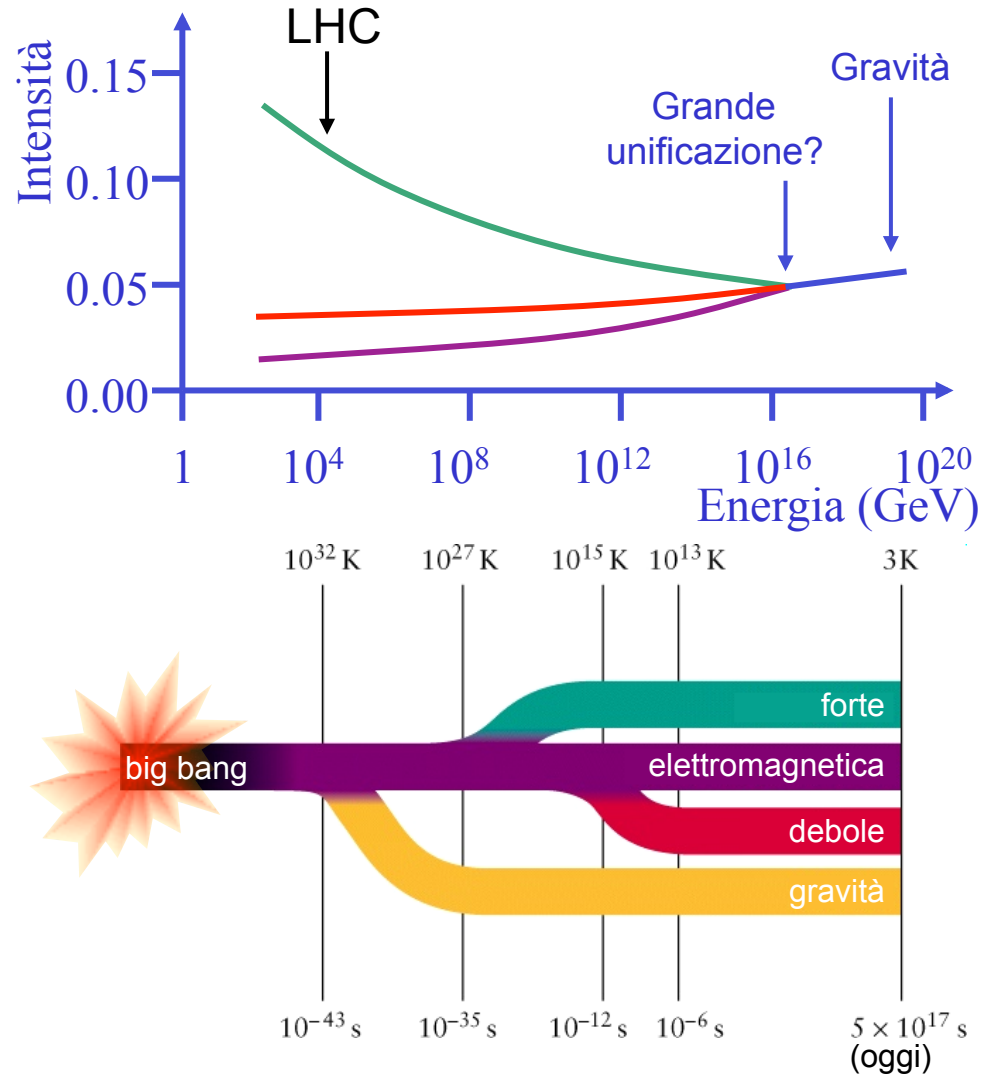
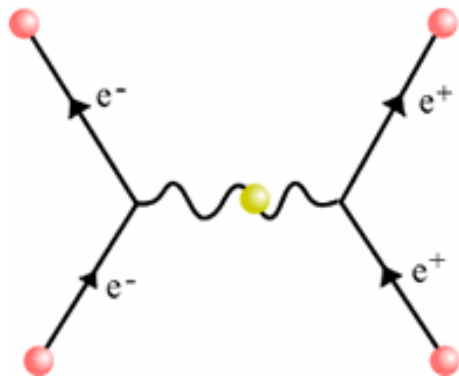

The Big Bang

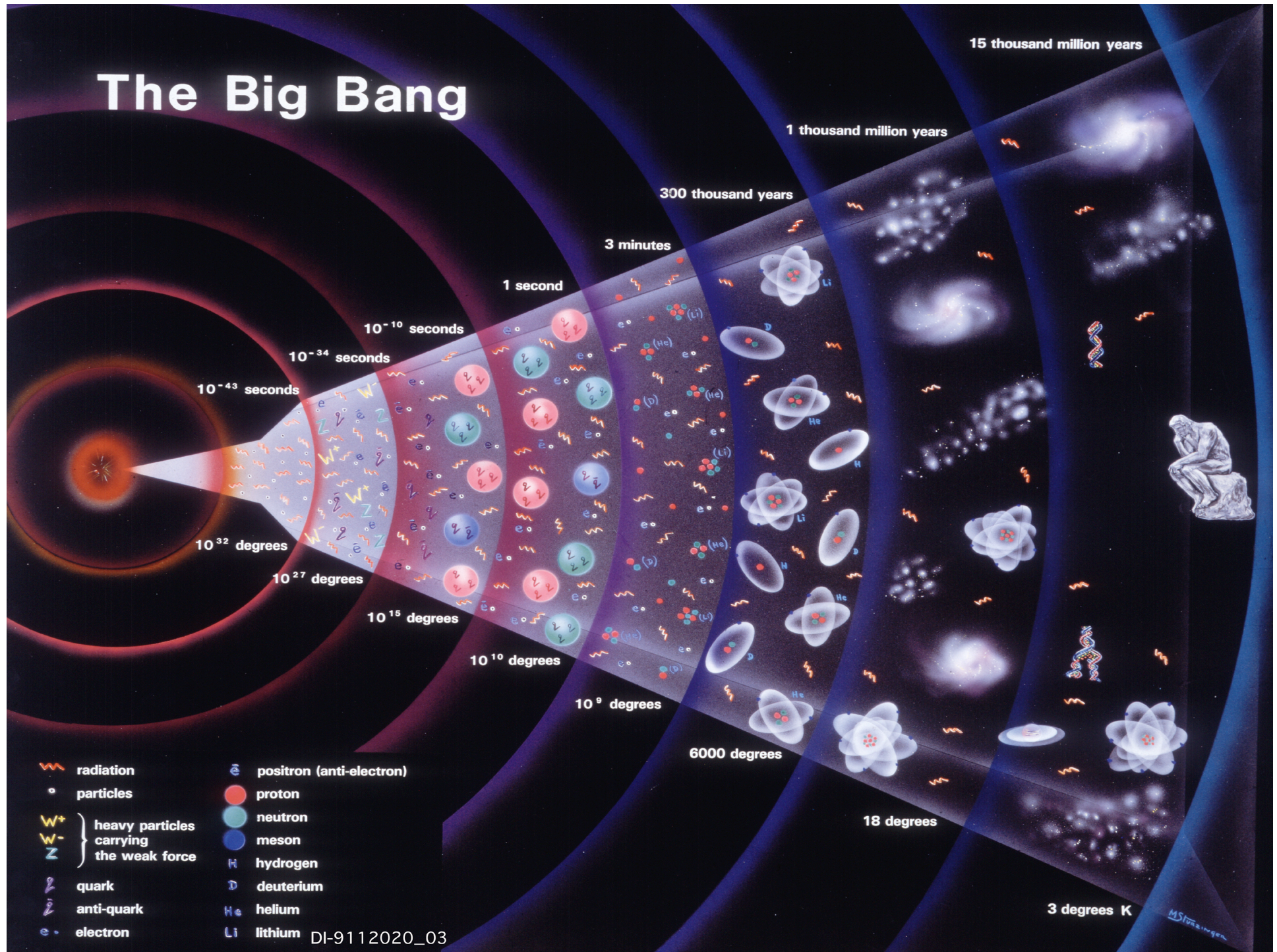

- | | |
|---|--------------------------|
| radiation | positron (anti-electron) |
| particles | proton |
| heavy particles carrying the weak force | neutron |
| | meson |
| | hydrogen |
| quark | deuterium |
| anti-quark | helium |
| electron | lithium |

DI-9112020_03

M. S. ...



Epoca di Plank ($<10^{-43}$ s)

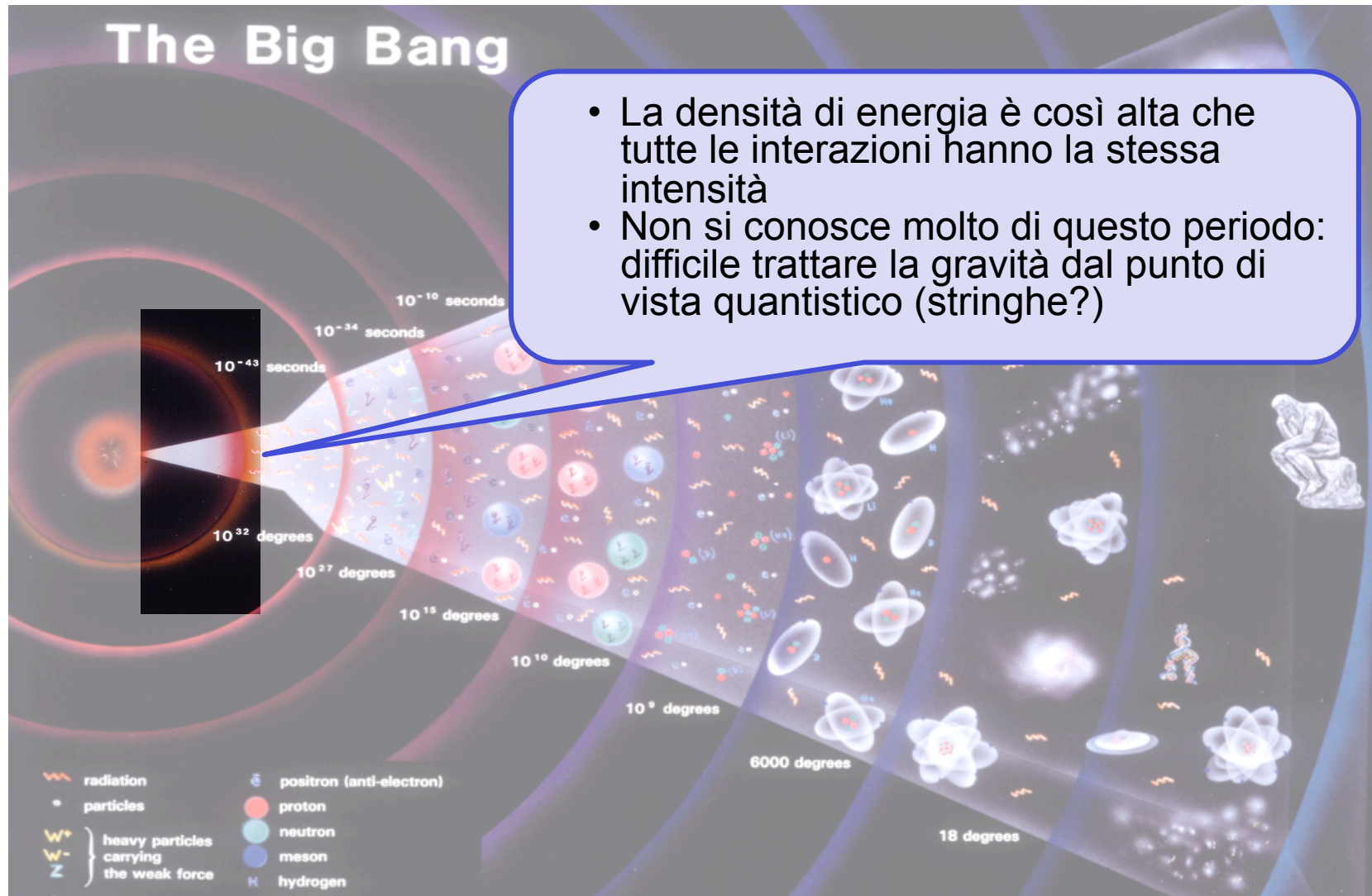





Epoca elettrodebole ($<10^{-12}s$)

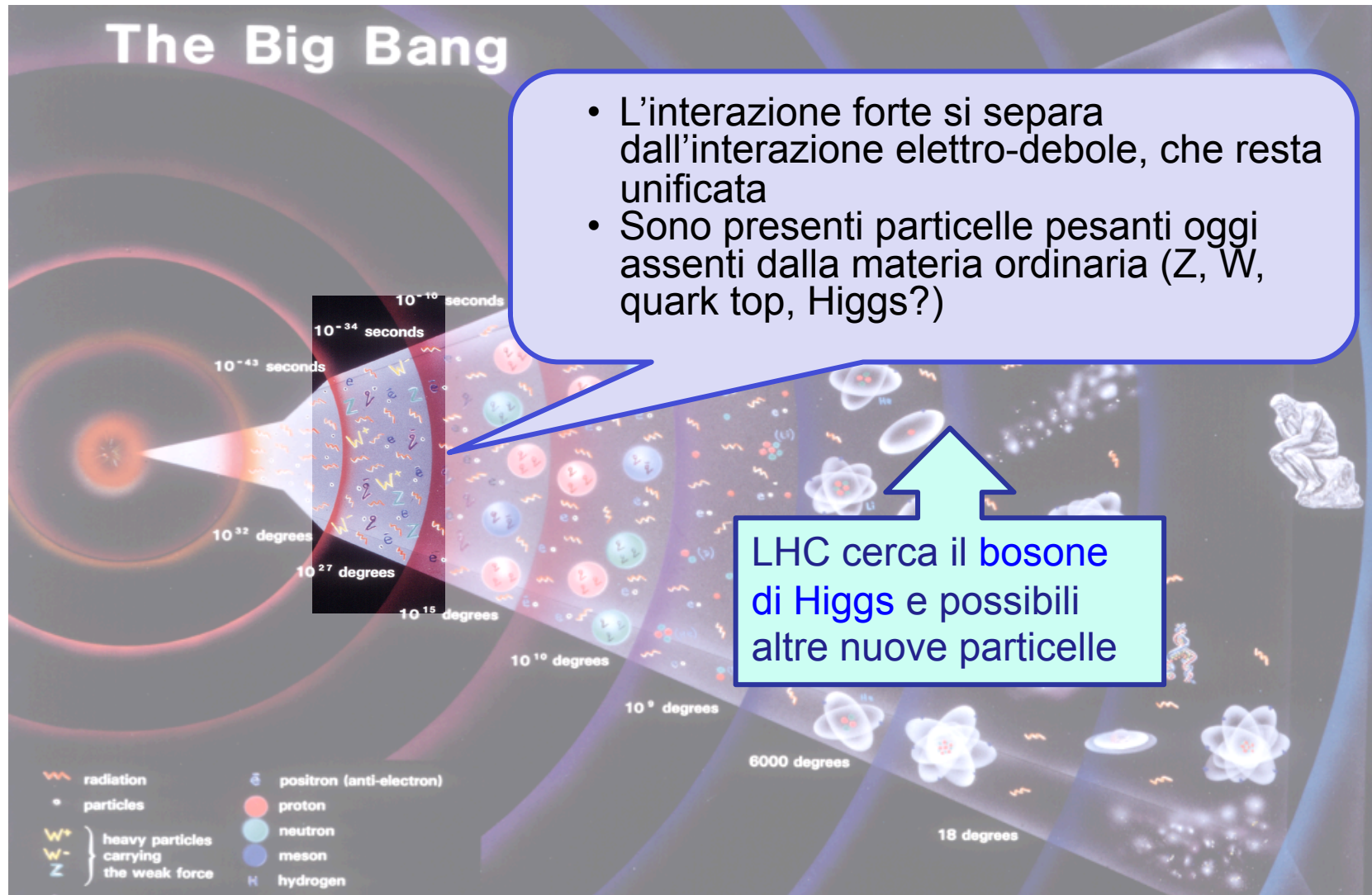



Quark-gluon plasma ($<10^{-6}s$)

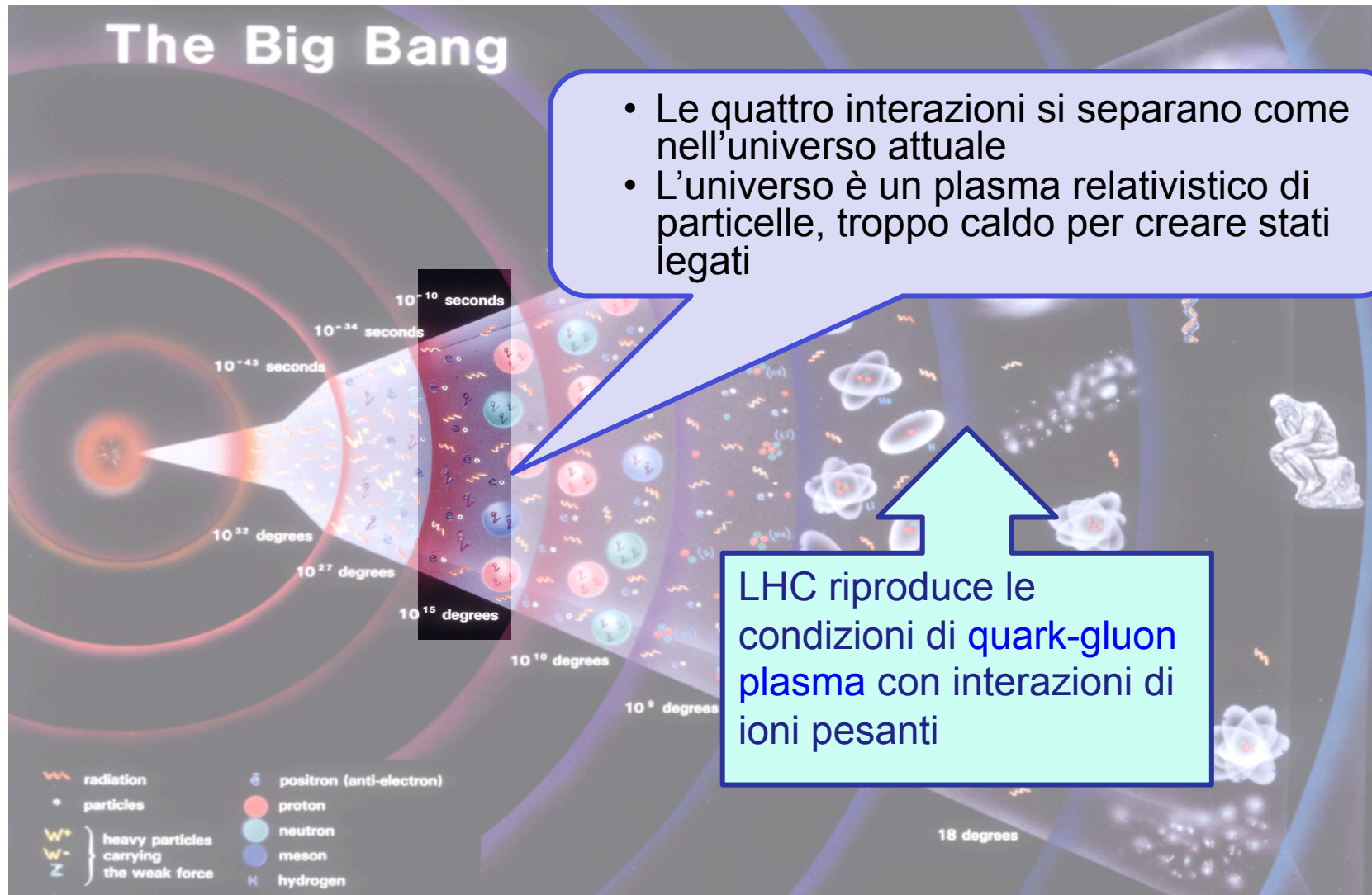

Bariogenesi (<1s)

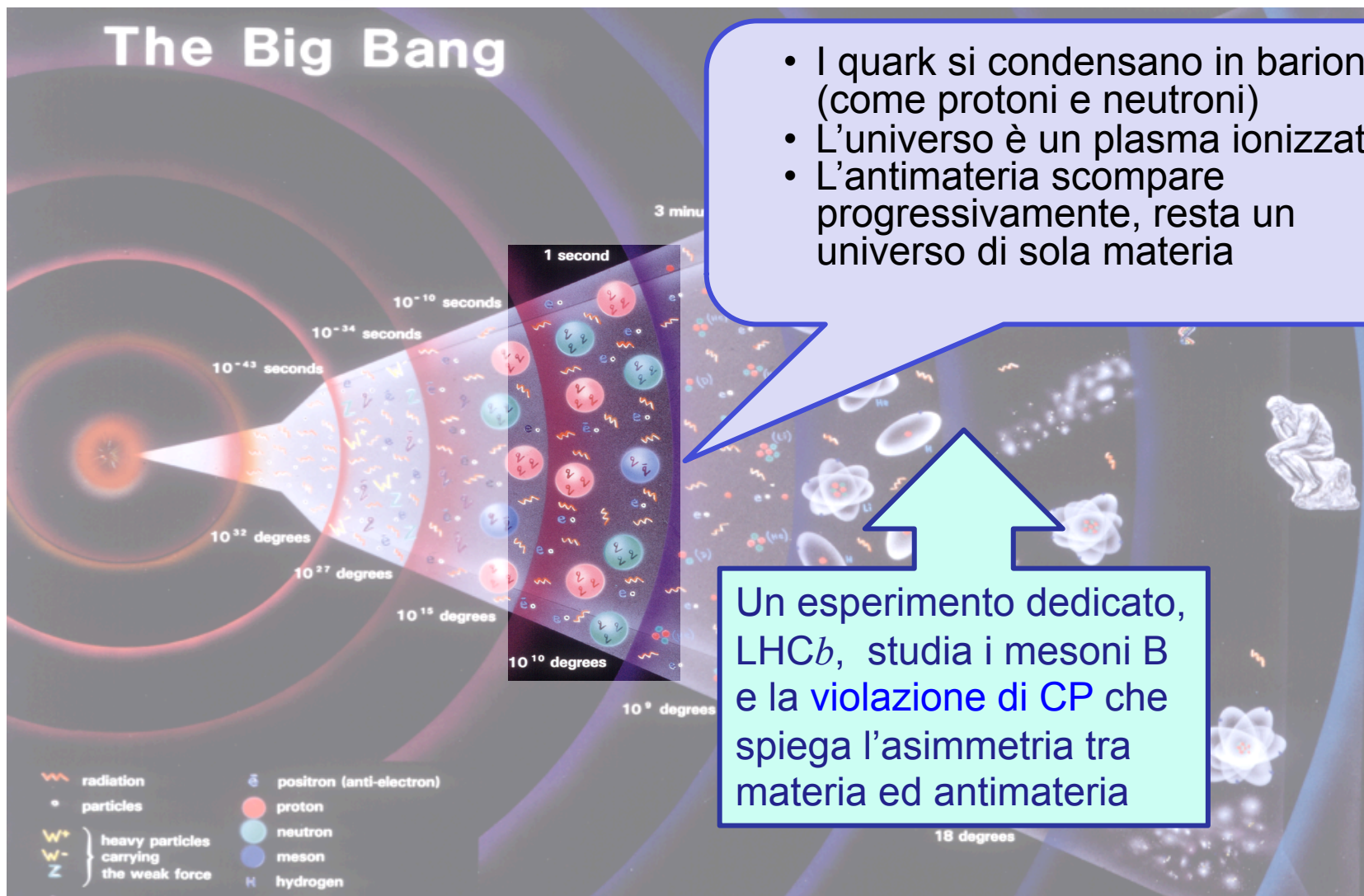

- I quark si condensano in barioni (come protoni e neutroni)
- L'universo è un plasma ionizzato
- L'antimateria scompare progressivamente, resta un universo di sola materia

Un esperimento dedicato, LHC**b**, studia i mesoni B e la **violazione di CP** che spiega l'asimmetria tra materia ed antimateria



Gli atomi (240000÷300000 anni)



- Gli elettroni si combinano con i nuclei di idrogeno e di elio e per formare atomi neutri
- I fotoni si disaccoppiano dalla materia (radiazione di fondo), l'universo diventa trasparente



Galassie ($>10^6$ anni)

- La gravità prevale sulla materia, ora neutra e la fa condensare
- si formano stelle e galassie
- I pianeti rocciosi si formeranno dopo le esplosioni delle prime supernovae
- Nasce la vita sulla terra

L'uomo costruisce LHC

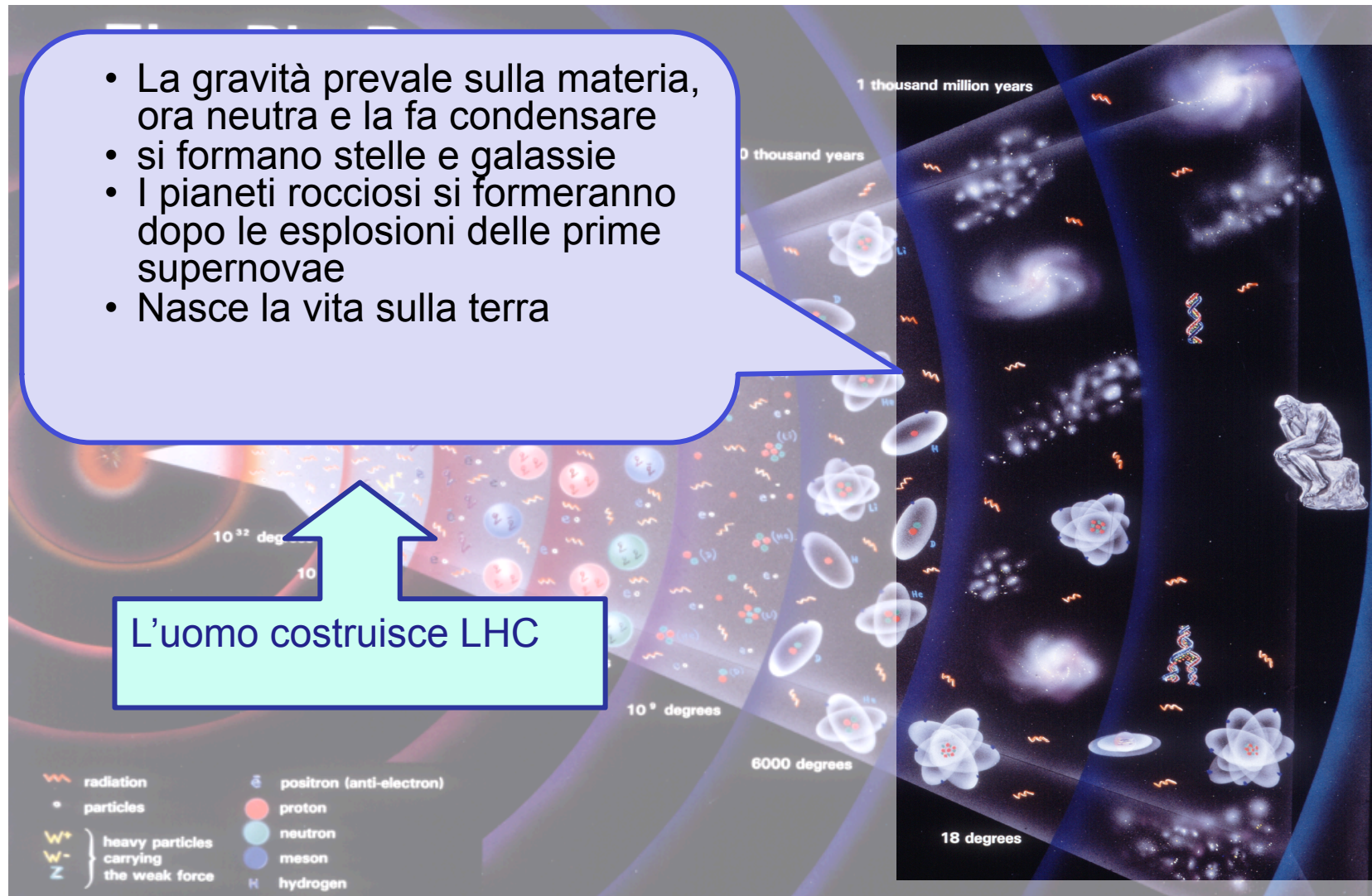



Altri problemi aperti



Unificazione e supersimmetria?



- Il Modello Standard non è compatibile, da solo con la grande unificazione
- Potrebbe essere necessario un ulteriore “ingrediente”: la supersimmetria?

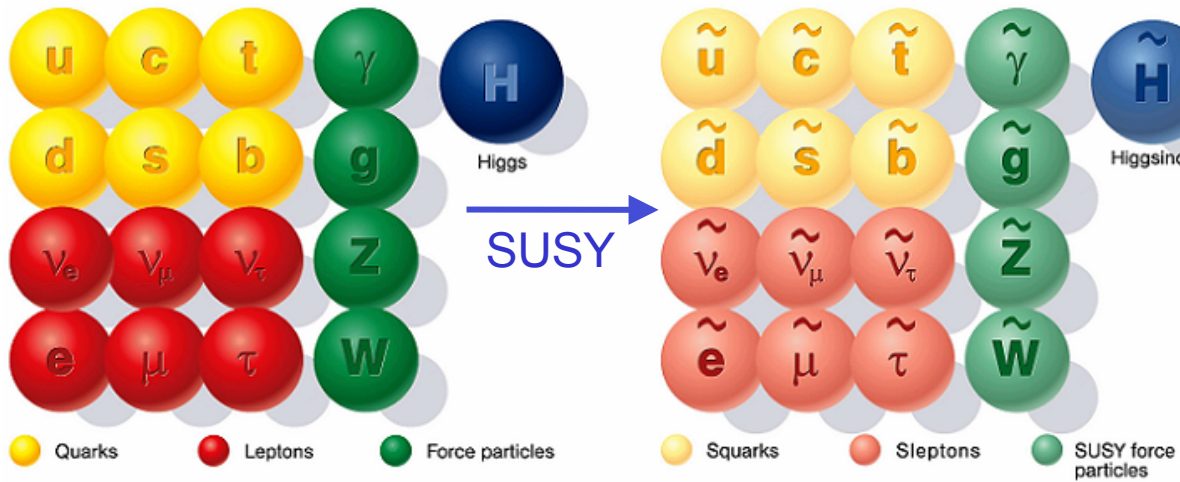
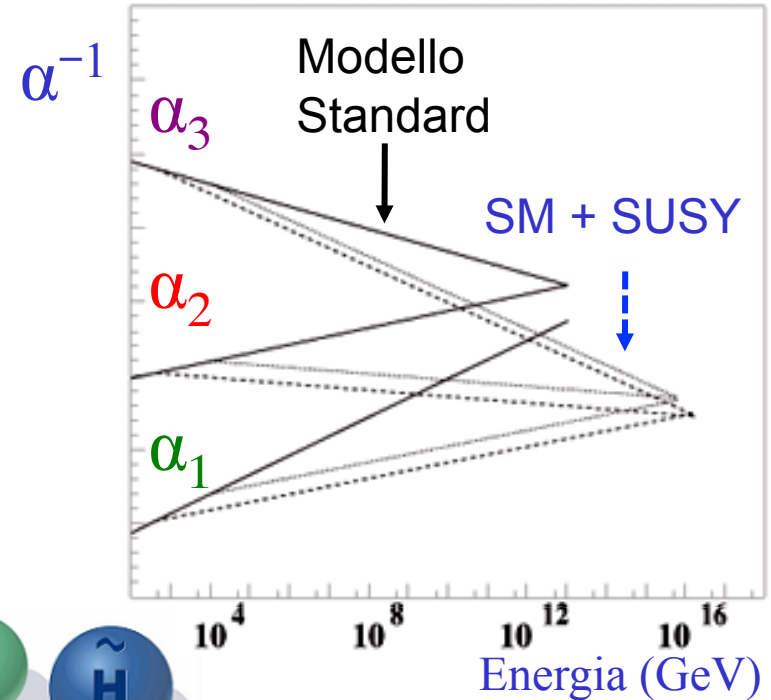

Lo spettro di particelle potrebbe moltiplicarsi con possibili osservazioni di nuove particelle ad LHC



Particelle SUSY

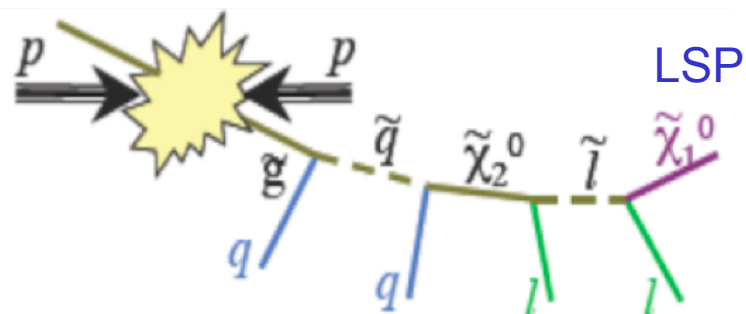

Names	Spin	P_R	Gauge Eigenstates	Mass Eigenstates
Higgs bosons	0	+1	$H_u^0, H_d^0, H_u^+, H_d^-$	h^0, H^0, A^0, H^\pm
squarks	0	-1	$\tilde{u}_L, \tilde{u}_R, \tilde{d}_L, \tilde{d}_R$ $\tilde{s}_L, \tilde{s}_R, \tilde{c}_L, \tilde{c}_R$ $\tilde{t}_L, \tilde{t}_R, \tilde{b}_L, \tilde{b}_R$	(same) (same) $\tilde{t}_1, \tilde{t}_2, \tilde{b}_1, \tilde{b}_2$
sleptons	0	-1	$\tilde{e}_L, \tilde{e}_R, \tilde{\nu}_e$ $\tilde{\mu}_L, \tilde{\mu}_R, \tilde{\nu}_\mu$ $\tilde{\tau}_L, \tilde{\tau}_R, \tilde{\nu}_\tau$	(same) (same) $\tilde{\tau}_1, \tilde{\tau}_2, \tilde{\nu}_\tau$
neutralinos	1/2	-1	$\tilde{B}^0, \tilde{W}^0, \tilde{H}_u^0, \tilde{H}_d^0$	$\tilde{N}_1, \tilde{N}_2, \tilde{N}_3, \tilde{N}_4$
charginos	1/2	-1	$\tilde{W}^\pm, \tilde{H}_u^\pm, \tilde{H}_d^\pm$	$\tilde{C}_1^\pm, \tilde{C}_2^\pm$
gluino	1/2	-1	\tilde{g}	(same)
goldstino (gravitino)	1/2 (3/2)	-1	\tilde{G}	(same)

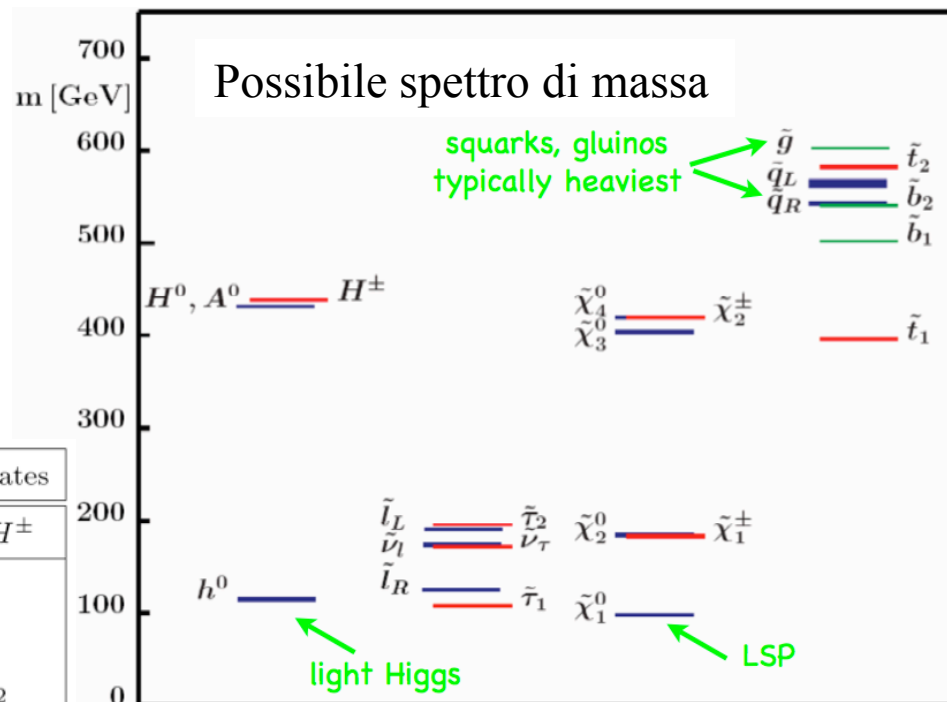

Due doppietti di Higgs
→ Higgs carico!



Un evento SUSY ad LHC



- Le particelle che sfuggono all'osservazione producono una energia mancante
- L'energia mancante si ricostruisce indirettamente dal bilancio di energia e momento

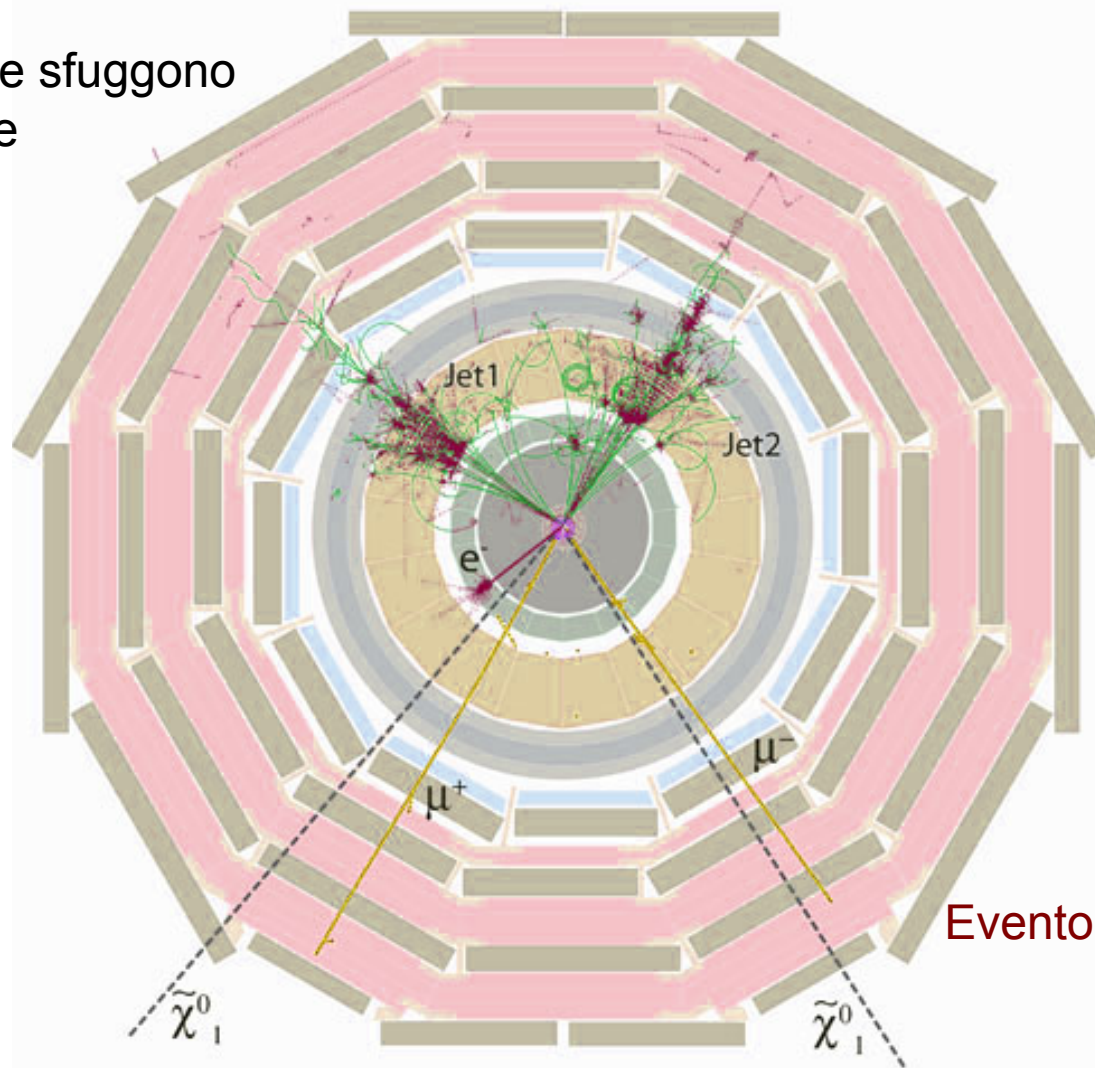



La materia oscura



- Stelle e pianeti costituiscono **solo il 5%** circa della massa e dell'energia dell'universo
- La restante massa **non è visibile** direttamente, ma solo attraverso i suoi **effetti gravitazionali** sul moto delle stelle nelle galassie

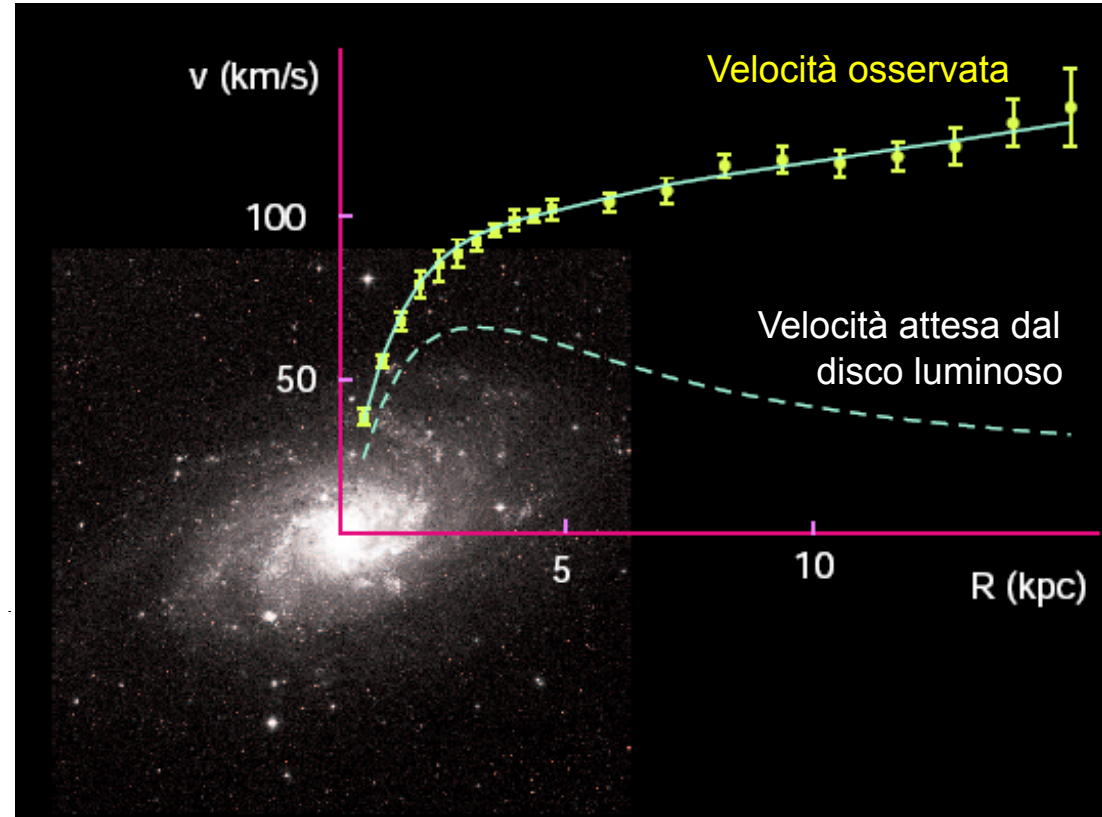
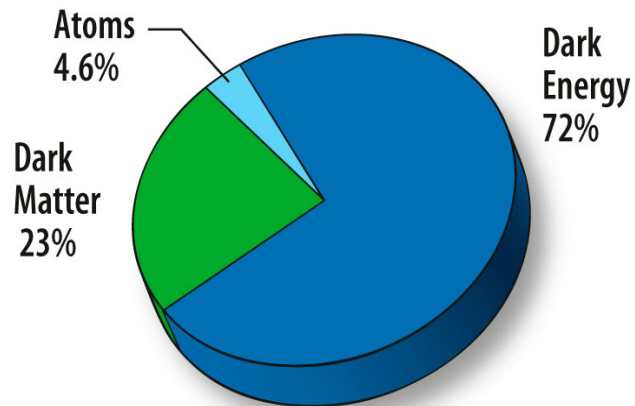

Curva di rotazione della galassia M33



Una “foto” della materia oscura

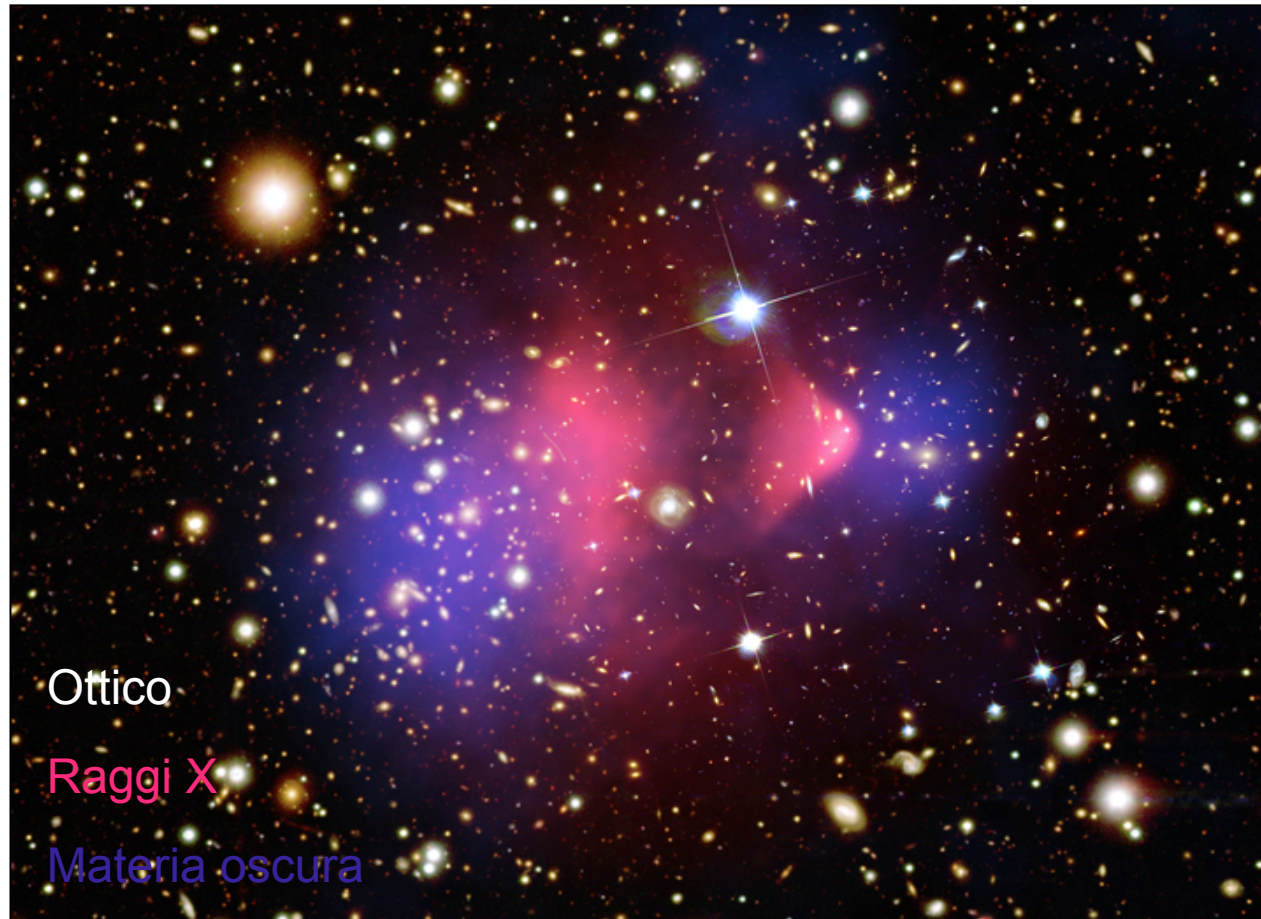

*CHANDRA, X-ray galaxy cluster
1E 0657-56, bullet cluster*

Due immagini: ai raggi X e guardando
l'effetto di lente gravitazionale



Osservazione di materia oscura?



- Esperimento DAMA al Gran Sasso

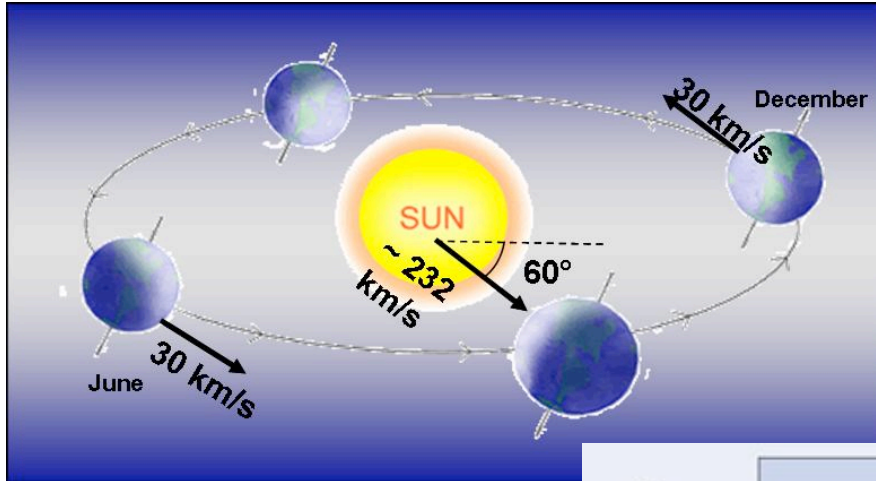

Significatività: 8.9σ

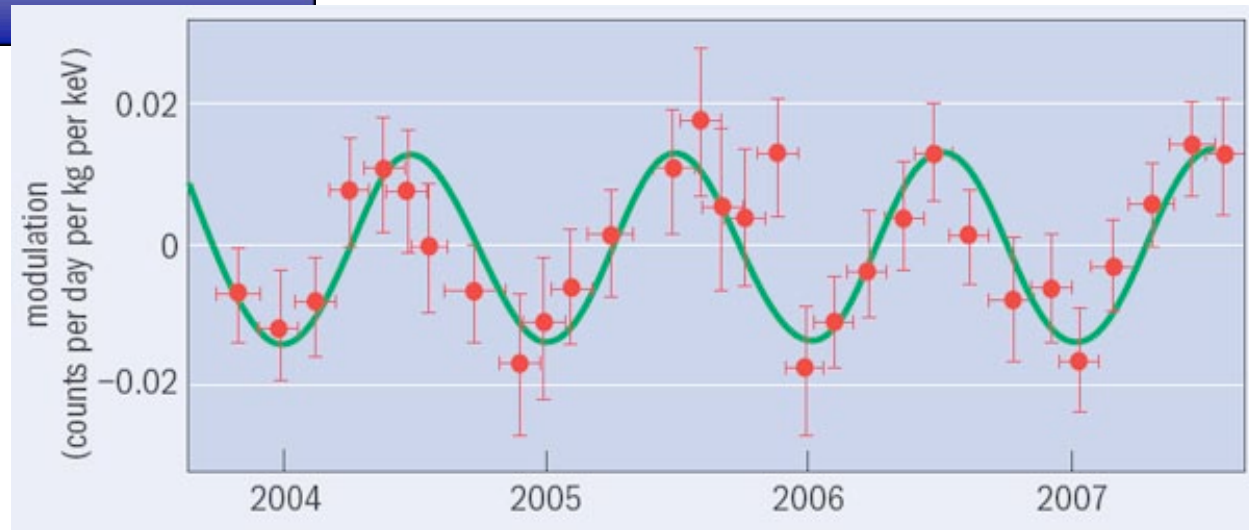



Unificare anche la gravità?



- Unificare anche la gravità richiede sormontare difficoltà teoriche per la sua trattazione quantistica
- Una teoria in studio tratta le particelle come oggetti non puntiformi, ma come **stringhe**

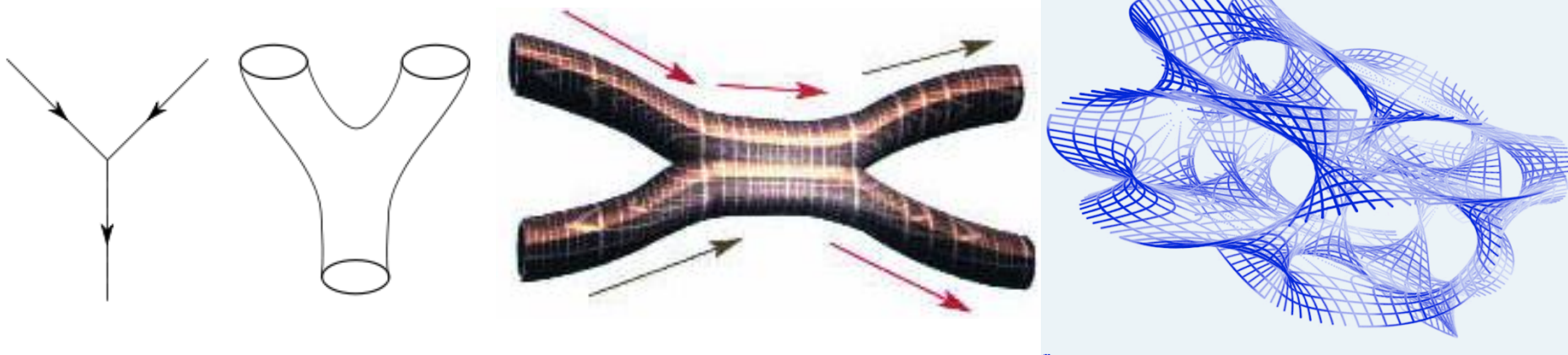

- Questi modello richiedono la presenza di **nuove dimensioni spazio-temporali**, e non sono ad oggi sufficientemente predittivi



Struttura dello spazio-tempo



- Diverse teorie prevedono l'esistenza di **nuove dimensioni spaziali**
- Le nuove dimensioni non sono accessibili nella nostra esperienza perché “**compattificate**”, con raggi di curvatura molto piccoli
- La presenza di nuove dimensioni si può manifestare con uno spettro di **nuove particelle** rivelabili ad LHC





Il modello di Kaluza-Klein



- Negli anni '20 fu proposto un modello per **unificare gravità ed elettromagnetismo** aggiungendo una quinta dimensione

4x4: equazioni di Einstein ← → 4x1: equazioni di Maxwell

$$\hat{g}^{\hat{\mu}\hat{\nu}} = \begin{pmatrix} g^{\mu\nu} & -A^\mu \\ -A^\nu & -\frac{1}{\phi} + A^2 \end{pmatrix}$$

- Se la quinta dimensione è 'compattificata', non sarebbe visibile
- In più, la compactificazione fornisce la **quantizzazione della carica elettrica**
- Il modello fu abbandonato per difficoltà nella trattazione quantistica, ora è stata riconsiderata nell'ambito di modelli più complessi



Particelle da extra dimensioni



- Ogni tipo di particella corrisponderebbe, nello spazio a 4 dimensioni, ad uno spettro di particelle, eccitate nella quinta dimensione

$$m^2 = m_0^2 + \frac{n^2}{R^2}$$

- Il partner del fotone ($n=1$) potrebbe essere un candidato per la materia oscura
- Nuove particelle potrebbero essere prodotte direttamente ad LHC (es.: Z')

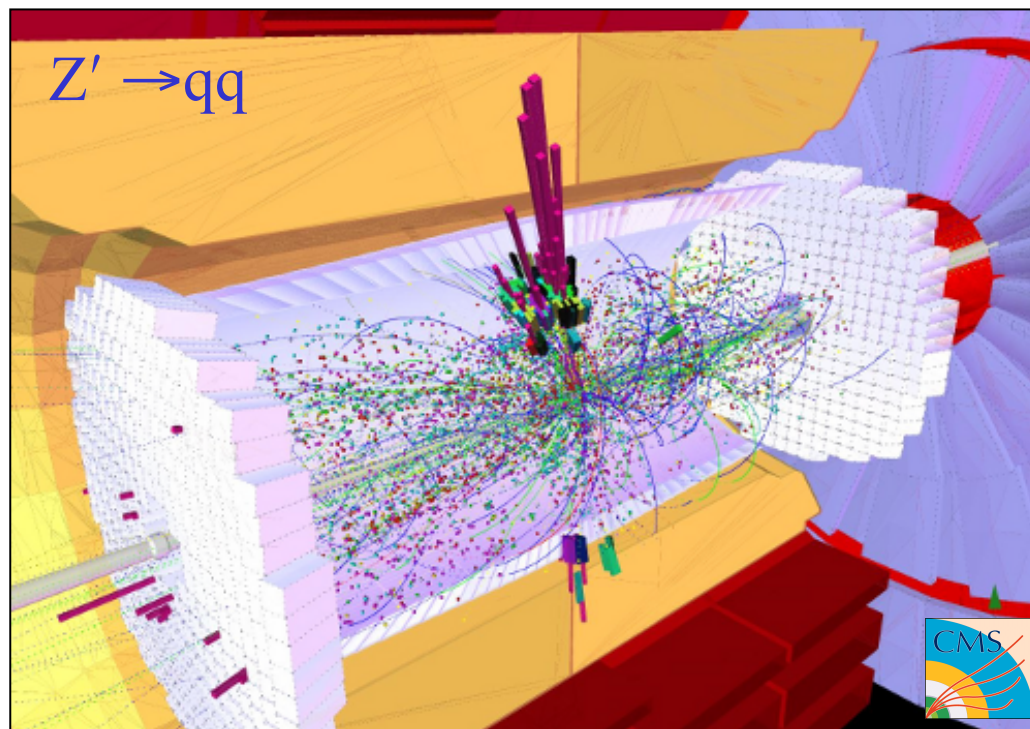



Conclusioni



- Il Modello Standard descrive tutte le particelle elementari e le interazioni note, ad eccezione della gravità
- Gran parte delle sue previsioni sono state verificate con gran precisione
- Manca l'osservazione del bosone di Higgs che potrebbe essere fatta ad LHC
- Restano aperti diversi problemi, tra cui la materia oscura, la grande unificazione, la trattazione quantistica della gravità
- LHC potrebbe fare luce su alcuni di questi problemi ancora aperti